



AQUACIAT™ LD ILD

Water chillers
Heat pump



Unit with protection grille option

Compact and silent

Scroll compressors

High-efficiency brazed-plate heat exchanger

All-aluminium micro-channel condenser

Self-adjusting electronic control

Cooling capacity, LD: 40 to 160 kW

Cooling capacity, ILD: 40 to 150 kW

Heating capacity, ILD: 40 to 150 kW



Cooling only



Cooling and heating



Hydronic module



Heat recovery

R-32 

USE

The new generation of **AQUACIAT** high-efficiency air-to-water heat pumps and water chillers offers an optimal solution for all heating and cooling applications used for the Healthcare, Office, and Hotel sectors.

These units are designed for outdoor installation and require no special protection against adverse weather conditions.

AQUACIAT is optimised for R-32, the environmentally-responsible fluid with the lowest GWP.

This range guarantees compliance with the most demanding requirements for increased seasonal energy efficiency (SEER and SCOP) and CO₂ reduction to comply with the various applicable European directives and regulations.

■ Self-regulating operation to adapt to seasonal variations and requirements

With exceptional SEER and SCOP seasonal energy efficiency levels, the **AQUACIAT** range offers the best technology combined with savings throughout the year.

Due to climatic variations and the different air-conditioning needs of tertiary buildings, most of the time water chillers and heat pumps run at partial load.

Equipped with multiple compressors, **AQUACIAT** units automatically adjust cooling capacity, anticipating variations in load and starting only the number of compressors needed to ensure optimum operation and energy efficiency.

Thanks to their exceptional thermodynamic performance, provided by radical selection of components, an electronic expansion valve as standard, and a specific control function, standard **AQUACIAT** units reach a high level of seasonal efficiency in cooling mode (SEER) and in heating mode (SCOP).

■ Acoustic comfort

With different levels of sound equipment available, the **AQUACIAT** range guarantees the acoustic comfort of occupants and meets the most sensitive environmental requirements as is the case in Hotels, Offices and Hospitals.

Use

■ Quick, simple installation

With a wide variety of connection accessories and equipment, the **AQUACIAT** range is quick and simple to install.

The advanced controller functions and different communication protocols enable local control via CMS/ BMS or remote control, providing building management with peace of mind.



OFFICES



HOTELS



HEALTHCARE

GLOBAL SYSTEM SOLUTIONS



As an expert on customised HVAC solutions, CIAT works to improve the well-being of individuals in their living areas or places of work. Aware of the thermal, energy and air quality issues faced today by every sector of activity, CIAT has responded by developing global systems based on an adapted and efficient combination of products. The latest-generation **AQUACIAT** with a low environmental footprint is part of our sustainable development process.

■ Global energy systems based on the water loop for heating, cooling and indoor air quality

To comply with today's thermal and environmental regulations, CIAT designs optimised water loop energy systems comprised of comfort units, heat pumps such as **AQUACIAT** and dual-flow air handling units. As a renewable resource and a highly effective heat-transfer fluid, water not only represents an excellent alternative to direct expansion systems, it also meets F-Gas regulations in terms of confinement and limitation of refrigerants within buildings.

■ Benefits of the water loop

- **More competitive:** Equipment that is more cost effective and requires less maintenance than direct expansion systems.
- **Greater comfort:** Flexible, precise control of occupant comfort.
- **Greater energy efficiency:** The homogeneity and the thermal stability of water reduce the energy requirements for transferring heat.
- **Environmentally sustainable:** No refrigerant is required on the premises and only a small amount is used in the heat pump installed outside the building's occupied spaces.
- **Easy to install:** No refrigerant specialists are required during installation.
- **Flexibility:** A water loop energy system adapts easily to the configuration of buildings and the changes that may be made to spaces over time.



RANGE

■ AQUACIAT LD/ILD series

In the **LD** water chiller & **ILD** standard reversible heat pump versions, **AQUACIAT** units are optimised to meet the most demanding technical and economic requirements.

■ Operation at high outdoor temperatures (options)

In this configuration, the **AQUACIAT** unit is optimised to operate at outdoor temperatures of +46°C in cooling mode. In this case, the machine is equipped with high-flow variable-speed fans, enabling a wider range of application while preserving the noise level under nominal outdoor conditions.

■ XtraLow Noise Units (option)

In this configuration, the compressors of the **AQUACIAT** unit are covered with a soundproofing jacket, the control of the variable-speed fans ensures the lowest noise level in all circumstances while preserving energy performance.

■ All-season operation (options)

In this configuration, the **AQUACIAT** unit is equipped with variable-speed fans and configured for optimal operation down to outdoor temperatures of -20°C in cooling mode.

DESCRIPTION

AQUACIAT units are packaged machines supplied as standard with the following components:

- Hermetic SCROLL compressors
- Brazed-plate condenser or evaporator water type heat exchanger
- All-aluminium micro-channel condenser (LD) or evaporator air-cooled exchanger, copper tube coil with aluminium fins (ILD) and axial fan motor assembly
- Electrical power and remote control cabinet:
 - 400V-3ph-50 Hz (+/-10%) mains power supply + earth
 - Transformer fitted as standard on the machine for supplying the remote control circuit with 24 V
- Connect Touch electronic control module
- Casing for outdoor installation

The entire **AQUACIAT** range complies with the following EC directives and standards:

- Machinery directive 2006/42/EC.
 - Electromagnetic compatibility directive 2014/30/EC
 - Safety of machinery: Electrical equipment of machines EN 60204-1
 - EMC immunity and emissions EN 61800-3 'C3'
 - Regulation (EC) No. 1907/2006 REACH
- Pressure equipment directive (PED) 2014/68/EU
- Refrigerating systems and heat pumps EN 378-2
 - Regulation (EU) No. 813/2013 implementing Directive 2009/125/EC with regard to ecodesign requirements (Heat pump)
 - Regulation (EU) No. 2016/2281 implementing Directive 2009/125/EC with regard to ecodesign requirements (Comfort Chiller and High Temperature Process Chiller)
 - Regulation (EU) No. 2015/1095 implementing Directive 2009/125/EC with regard to ecodesign requirements (Low and Medium Temperature Process Chiller)

DESCRIPTION

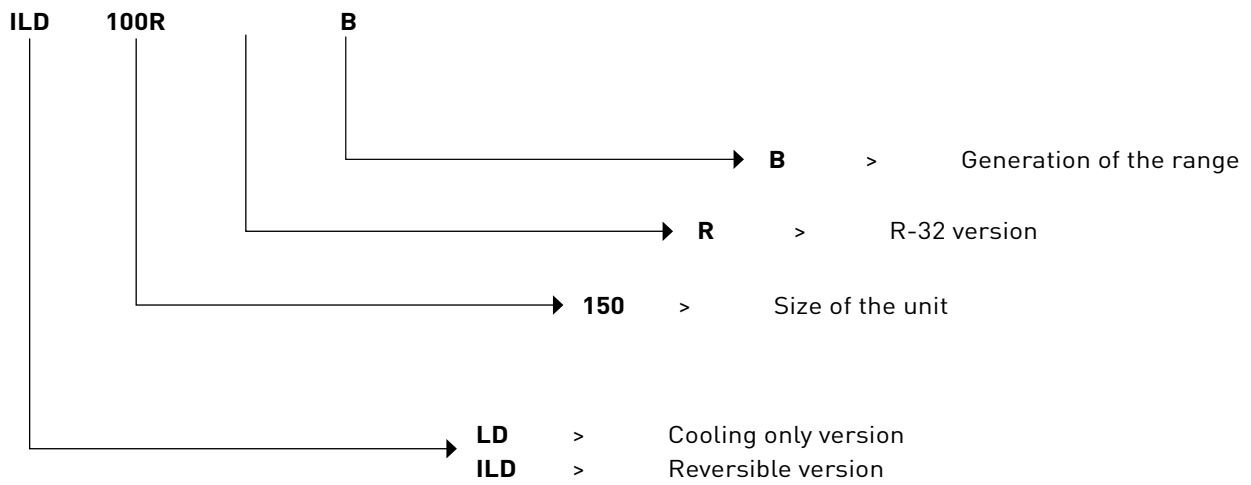

CONFIGURATION

LD-ILD	Standard version
LD-ILD, XLN option	Xtra Low Noise version



CUSTOMER BENEFITS

Environmental responsibility

We are committed to meeting your strictest environmental requirements.

We focus our energies on making our products ever more efficient and environmentally friendly.

AQUACIAT exceeds the requirements of the 2021 Ecodesign regulations.



Simplicity

To save you time, we guarantee easy installation and integration in the building management system.

- No machine room required for the pumps and other accessories thanks to the hydronic module option available across the entire range.
- Optimum use of the surface area for easy integration into an existing building.
- Quick, easy installation and commissioning.
- Single-unit solution for quick commissioning and reliable installation.
- Communication with all types of building management system (BMS) via Modbus protocol available as standard, or optional LON or BACNET protocols.



User comfort

We guarantee acoustic comfort for your users.

Thanks to our low-noise fans installed as standard and the noise-reducing technologies integrated in the new **AQUACIAT** range, we guarantee the level of acoustic comfort which meets your user requirements.

Our optional variable-speed fans reduce the noise level at partial load (night, mid-season, etc.).



XTRA LOW NOISE LEVEL

-9 dB(A)

Compressors and all noise-generating components equipped with reinforced noise insulation

NIGHT MODE



Sound level reduction

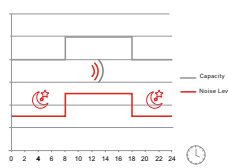

Reliability

We use state-of-the-art monitoring solutions to guarantee complete reliability for your equipment.

ABOUND HVAC Performance lets you track and monitor your CIAT equipment.

- Data extraction in real time via customised access to the **ABOUND HVAC Performance** website (controller dashboard, temperature/event curve, fault memory and alerts and parameter history).
- Email alerts for equipment incidents.
- Monthly and annual reports with analysis and recommendations from CIAT experts



Energy savings

We develop solutions to enable substantial savings while protecting the environment and guaranteeing user comfort.

The partial heat recovery option allows additional hot water to be produced free of charge and at a higher temperature. This hot water can be used to prepare domestic hot water for heating swimming pools, spas and hot tubs.



100 % Chilled or hot water production



25 % Domestic hot water production

DESCRIPTION OF THE MAIN COMPONENTS

■ Compressors

- Hermetic SCROLL type
- Electronic motor overheating protection
- Crankcase resistance (**AQUACIAT ILD**)
- Mounted on anti-vibration mounts

■ Water type heat exchanger

- Brazed-plate exchanger
- Condenser or evaporator mode exchanger on the reversible heat pump version
- Plate profile for high-performance optimisation
- 19-mm armaxflex thermal insulation
- Frost protection with heater

■ Air-cooled exchanger

- Air-cooled exchanger:
 - All-aluminium micro-channel coil, cooling only version
 - Copper tube coil with aluminium fins, reversible heat pump version
- Condenser or evaporator mode exchanger on the reversible heat pump version
- Propeller fans with composite blades offering an optimised profile, fixed-speed as standard or variable-speed as an option
- Motors – IP 54, class F

■ Refrigerant accessories

- Dehumidifier filters
- Hygroscopic sight glasses
- Electronic expansion valves
- Service valves on the liquid line
- 4-way cycle inversion valves in cooling/heating mode on the reversible heat pump version

■ Regulation and safety instruments

- Low and high pressure sensors
- Relief valves on the refrigerant circuit
- Water temperature control sensors
- Evaporator antifreeze sensor
- Factory-fitted evaporator water flow controller

■ Electrical cabinet

- Electrical cabinet with IP 44 protection rating
- A connection point without neutral
- Front-mounted main safety switch with handle
- Control circuit transformer
- 24 V control circuit
- Fan and compressor motor circuit breaker
- Fan and compressor motor contactors
- Connect Touch microprocessor-controlled electronic control module
- Wire numbering
- Marking of the main electrical components

■ Frame

Frame made from RAL7035 light grey & RAL 7024 graphite grey painted panels.

■ Connect Touch control module

- User interface with 4.3-inch touch screen
- Intuitive, user-friendly navigation using icons
- Clear text display of information available in 6 languages (F-GB-D-E-I-NL)



DESCRIPTION OF THE MAIN COMPONENTS

The electronic control module performs the following main functions:

- Regulation of the water temperature (at the return or at the outlet)
- Regulation of the water temperature based on the outdoor temperature (water law)
- Regulation for low temperature energy storage
- Second setpoint management
- Complete management of compressors with start-up sequence, timer and runtime balancing
- Self-regulating and proactive functions with adjustment of the control to counter parameter drift
- Optimised defrosting with free defrost function to optimise performance at partial load and the SCOP
- In-series staged power control system on the compressors according to the thermal requirements
- Management of compressor short cycle protection
- Frost protection (exchanger heaters)
- Compressors phase reversal protection
- Management of occupied/unoccupied modes (according to the time schedule)
- Compressor and pump runtime balancing
- Management of the machine operation limit according to outdoor temperature
- Sound level reduction device (night mode according to the user programme) with limitation of compressor capacity and fan speed
- Diagnostics of fault and operating statuses
- Management of a fault memory allowing a log of the last 50 incidents to be accessed, with operating readings taken when the fault occurs
- Blackbox memory
- Lead/Lag management of the two machines in parallel with runtime balancing and automatic changeover if a fault occurs on one machine
- Weekly and hourly time schedule for the machine, including 16 periods of absence
- Pump standby based on demand (energy saving)
- Calculation of the water flow rate and operating pressure (hydraulic module version)
- Electronic adjustment of the water pump speed and water flow rate (variable-speed pump option)
- Display of all machine parameters (3 access levels, User/Maintenance/Factory, password-protected): temperature, setpoints, pressures, water flow rate (hydraulic version), runtime.
- Display of trend curves for the main values
- Storage of maintenance manual, wiring diagram and spare parts list.

■ Remote management

Connect Touch is equipped as standard with an RS485 port and an ETHERNET (IP) connection, offering a range of options for remote management, monitoring and diagnostics.

Using the integrated Webserver, a simple internet connection uses the unit's IP address to access the Connect Touch interface on the PC, facilitating everyday management tasks and maintenance operations.

A range of communication protocols are available: MODBUS/JBUS RTU (RS485) or TC/IP as standard, LONWORKS – BACNET IP as an option, enabling most CMS/BMS to be integrated.

Several contacts are available as standard, enabling the machine to be controlled remotely by wired link:

- Automatic operation control: When this contact is open, the machine stops
- Heating/cooling operating mode selection
- Setpoint 1/setpoint 2 selector: When this contact is closed, a second cooling setpoint is activated (energy storage or unoccupied mode, for example)
- Power limitation: Closing the contact concerned allows the power or refrigerating consumption of the machine to be limited by stopping one or more compressors (this limit can be set with a parameter)
- Fault reporting: This contact indicates the presence of a major fault which has caused one or both refrigerant circuits to stop
- Operational status reporting indicates that the unit is in production mode.
- Activation control for partial energy recovery using the desuperheater
- Switch control for the customer pump, external to the machine (on/off).
- 0-10V output available for control of a variable flow pump (unit without hydronic module)

DESCRIPTION OF THE MAIN COMPONENTS

Contacts available as an option:

- Setpoint adjustable via 4-20 mA signal: This input is used to adjust the setpoint in COOLING mode
- On/off control for a boiler
- 4-stage on/off management for additional heaters.

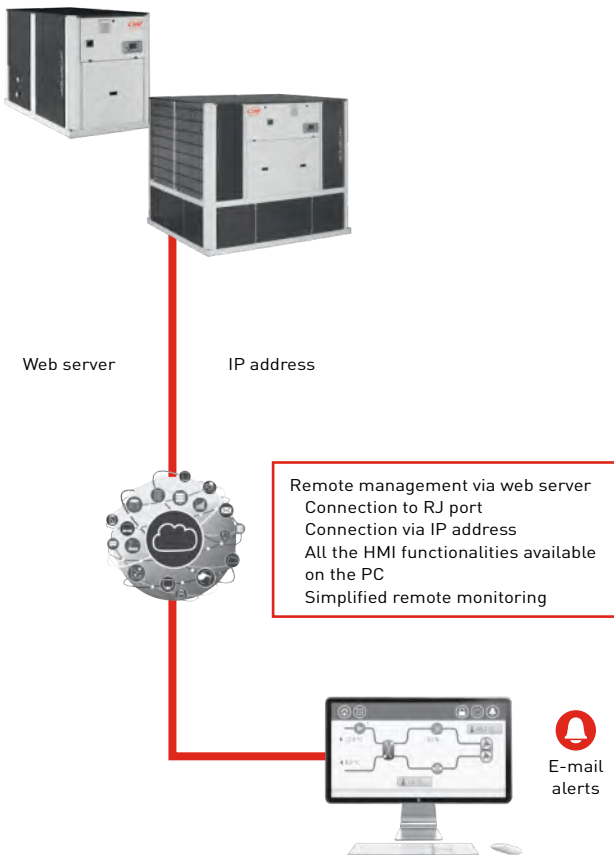

■ Maintenance

Connect Touch has two maintenance reminder functions as standard, making users aware of the need to regularly perform maintenance operations and to guarantee the service life and performance of the unit. These two functions can be activated independently.

A reminder message appears on the unit's HMI screen, and stays there until it is acknowledged by the maintenance operator. The information and alert relating to these functions are available on the communication bus to be used on the CMS/BMS.

- The scheduled maintenance reminder: When activated, this function enables the period between two maintenance inspections to be set. This period may be set by the operator in either days, months or operating hours, depending on the application.
- The compulsory F-GAS sealing test maintenance reminder: When activated, this function, which is the default factory setting, enables the period between two sealing tests to be selected, based on the unit's refrigerant charge, in compliance with the F-GAS regulations

■ SGR Ready

- Heat pump **AQUACIAT ILD** are SGR ready certified, standardized and secured label for integration on the smart electrical networks.



DESCRIPTION OF THE MAIN COMPONENTS

Complete reliability thanks to state-of-the-art monitoring solutions: **ABOUND HVAC Performance**

■ **ABOUND HVAC Performance, the CIAT supervision solution**

ABOUND HVAC Performance is a remote supervision solution dedicated to monitoring and controlling several CIAT machines in real time.

Advantages

- Access to the operating trend curves for analysis
- Improved energy performance
- Improved availability rate for the machines

Functions

ABOUND HVAC Performance will send data in real time to the supervision website.

The machine operating data can be accessed from any PC, smartphone or tablet.

Any event can be configured to trigger a mail alert.

Parameters monitored:

- Overview
- Control panel for the controllers
- Events
- Temperature curves

Monthly and annual reports are available to analyse:

- The performance and operation of the machine
Example: operating curves and time, number of compressor start-ups, events, preventive maintenance actions to be performed, etc.

Incidents such as a drift in the measurements on a temperature sensor, incorrectly set control parameters, or even incorrect settings between one compressor stage and the other are immediately detected, and the corrective actions put in place.

Compatibility

Up to 3 machines per box

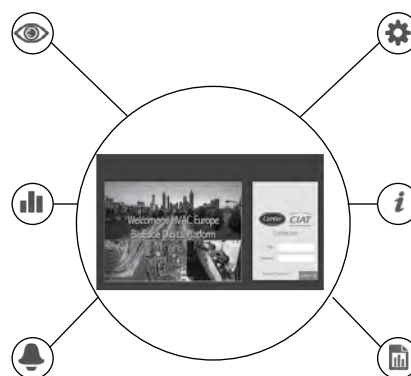
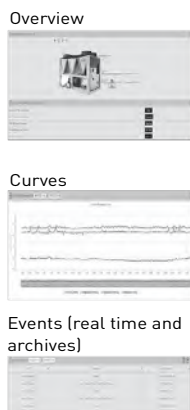

Supervision platform
ABOUND HVAC Performance



Equipment

This box can be used on both machines which are already in use (existing inventory), or on new machines.

- 1 transportable cabinet

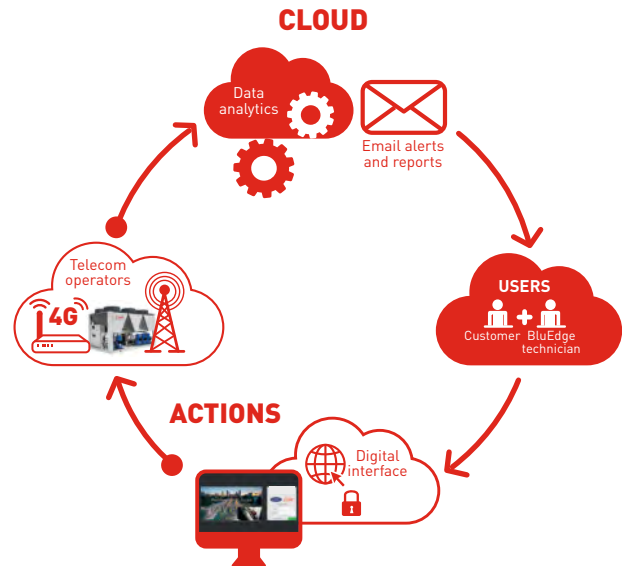

Composition of the box (available in 230 V and 400 V)

- 1 GPRS / 4G LTE-M modem
- 1 SIM SMART card
- 1 24-VDC power supply
- 1 power protection device
- 1 GSM antenna
- Rail mounting
- Enclosed casing to protect the equipment during transport
- Packing box for cable routing (bus, power supply)



SEASONAL PERFORMANCE IN COOLING MODE

Analyses of installed systems show that the heat load varies from season to season and that a water chiller operates at reduced capacity for the majority of the time. Partial load efficiency is therefore essential when choosing a water chiller. It is with this in mind that the new **AQUACIAT** range was designed. In particular, the entire range uses R32 refrigerant which, thanks to its thermodynamic performance, makes it possible to obtain much higher seasonal performance levels.

As the compressors are connected in parallel on the refrigerating circuit, the **AQUACIAT** easily and efficiently adjusts the cooling capacity to the system's needs. The self-adjusting Connect Touch control anticipates variations in load and starts only the number of compressors needed. This ensures optimum operation of the compressors and guarantees energy efficiency for the majority of the system's life.

In the high seasonal energy efficiency configuration, **AQUACIAT** has variable-speed fan motor assemblies. This technology enables the machine's partial load performance to be improved, along with its seasonal performance (SEER, SEPR and SCOP).

The **(Seasonal Energy Efficiency Ratio (SEER))** measures the seasonal energy efficiency of liquid chillers for **comfort applications** by calculating the ratio between the annual cooling demand of the building and the chiller's annual energy demand. It takes into account the energy efficiency for each outdoor temperature weighted by the number of hours observed for each of these temperatures, using actual climate data.

The **SEER** is a new way of measuring the energy efficiency of liquid chillers for **comfort applications** over an entire year. The new indicator provides a more realistic overview of the cooling system's energy efficiency and its actual impact on the environment (Ecodesign regulation 2016/2281).

MEPS ⁽¹⁾ relating to EU ecodesign for chillers with air cooled condensers		Level 2 (from 01/01/2021)
SEER for comfort Chillers < 400 kW	kWh/kWh	4,09
SEER for comfort Chillers > 400kW	kWh/kWh	4,55

(1) Minimum energy performance standards set by EU member states to comply with the EU Ecodesign directive. SEER for the comfort chiller.

AQUACIAT LD units comply with Ecodesign regulation 2016/2281



The **(Seasonal Energy Performance Ratio) (SEPR)** measures the seasonal energy efficiency of liquid chillers for process applications by calculating the ratio between the annual process cooling demand and the chiller's annual energy demand. It takes into account the energy efficiency at each outdoor temperature for the average European climate weighted by the number of hours observed for each of these temperatures.

The **SEPR** is a new way of measuring the energy efficiency of liquid chillers for **process applications** over an entire year. The new indicator provides a more realistic overview of the cooling system's energy efficiency and its actual impact on the environment (Ecodesign regulation 2015/1095 and 2016/2281).

MEPS ⁽¹⁾ relating to EU ecodesign for chillers with air cooled condensers		Level 2 (since 01/07/2018)
SEPR for kWh/kWh < 300 kW Medium Temperature Process Chillers	kWh/kWh	2,58
SEPR for kWh/kWh > 300 kW Medium Temperature Process Chillers	kWh/kWh	3,22
MEPS ⁽¹⁾ relating to EU ecodesign for chillers with air cooled condensers		Level 2 (from 01/01/2021)
SEPR for kWh/kWh < 400 kW High Temperature Process Chillers	kWh/kWh	5,00
SEPR for kWh/kWh > 400 kW High Temperature Process Chillers	kWh/kWh	5,50

(1) Minimum Efficiency Performance Standards: Performance standards set by EU member states to comply with the EU Ecodesign directive. SEPR for the Process chillers.



SEASONAL PERFORMANCE IN HEATING MODE

The **(Seasonal Coefficient Of Performance) (SCOP)** measures the seasonal energy efficiency of heat pumps in heating mode.

The European Ecodesign directive considers the product's environmental impact throughout its entire life cycle. It defines the mandatory energy efficiency requirements for water chillers and heat pumps.

Products that do not meet the energy efficiency requirements set by the new directive will gradually be phased out of the market, forcing manufacturers to develop and offer more efficient products.

Like the SEER relating to water chillers, the new seasonal coefficient of performance (SCOP) resulting from this new European directive is used to evaluate the energy efficiency of heat pumps. Until now, only the COP has been used to measure energy efficiency in heating mode.

The COP was exclusively calculated using a single measuring point, and only took into account operation at full load, which did not represent the efficiency of the heat pump over an entire heating season.

The purpose of the SCOP is to characterise the seasonal efficiency of the heat pump by taking into account the efficiency at partial load and full load established for several outdoor temperatures. The SCOP is the ratio between the building's annual heating demand and the annual electricity consumption of the heating system. It is measured in accordance with the EN14825 standard based on an average reference climate that takes into account several reference temperatures between -10°C and +16°C

■ Primary energy evaluation

In order to compare the energy efficiency of products using different energy sources, the Ecodesign directive introduced a new seasonal energy efficiency calculation known as η_s (Greek letter eta followed by the letter "s" for seasonal) and expressed as a percentage. For heat pumps, the SCOP (final energy) value is transposed to η_s (primary energy) by taking into account a conversion coefficient of 2.5 which corresponds to the average efficiency of the electrical production and various corrections for the responsiveness of the regulation system ($i = 3$ for air-to-water heat pumps).

$$\eta_s (\%) = \frac{\text{SCOP(kW/kW)} \times 100}{2,5} - \sum F_i \text{ corrections}$$

The minimum seasonal efficiency requirements to be met by low temperature heat pumps, set by the standard, are as follows:

MEPS ⁽¹⁾ relating to EU ecodesign for air-to-water heat pumps	Level 2 (since 09/2017)	
	Space & Hot Water 47/55 °C	Space Heating 30/35°C
SCOP for heat pump < 400 kWh/kWh	2,83	3,20
EtasS	110	125

(1) Minimum Efficiency Performance Standards: Performance standards set by EU member states to comply with the EU Ecodesign directive. SCOP for the comfort heat pump

AQUACIAT ILD units comply with Ecodesign regulation 813/2013.



ENVIRONMENTAL RESPONSIBILITY

The **AQUACIAT** contributes to sustainable development via an environmentally responsible approach, aimed at balancing ecological and economic concerns. This enables it to meet the requirements of future European thermal regulations and to protect our environment for future generations.

The impact of an air conditioning system on global warming of the planet is in large part caused by CO₂ emissions released into the atmosphere when the electricity required to power the unit is produced (indirect effect) and in small part by CO₂ emissions linked to uncontrolled emissions of refrigerant with global warming potential into the atmosphere (direct effect).

With **AQUACIAT**, it's a win-win situation: Its low charge of R-32 refrigerant with low GWP reduces the direct environmental impact by 80% while reducing the indirect environmental impact thanks to its high energy performance.

■ 77% reduction in the direct environmental impact (refrigerant)

This performance is the result of the high-quality components used, which have all been rigorously selected:

- R-32 refrigerant with low environmental impact (Ozone depletion potential =0, Global warming potential =675)
- Aluminium micro-channel coil on LD chiller versions with a 40% reduction in refrigerant charge compared to a conventional coil
- New generation of copper tube coil-aluminium fins on ILD heat pump versions with a 30% reduction in refrigerant charge compared to a conventional coil
- Asymmetrical brazed-plate heat exchanger (BPHE) with a reduction in the refrigerant charge compared to a shell and tube heat exchanger
- Systematic tightness check of units in leak detection cabinets at end of line production

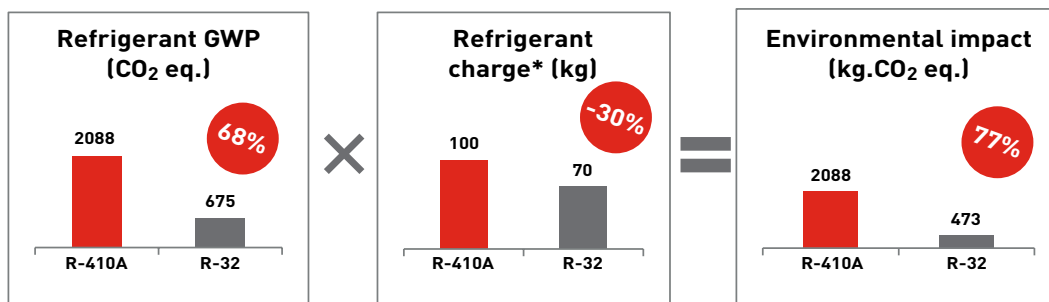

In conclusion, the direct environmental impact potential of the AQUACIAT with R-32 refrigerant is reduced by 77% compared to the previous R-410A generation.

ENVIRONMENTAL RESPONSIBILITY

■ Reduced indirect environmental impact (Energy)

The high energy performance offered by **AQUACIAT R-32** enables energy consumption to be greatly reduced, thereby cutting energy bills for the user whilst reducing the unit's carbon footprint.

The seasonal efficiency of the **AQUACIAT R-32** in cooling mode is 8% greater than that of the previous version with R-410A and 5% greater in heating mode.

In addition, the **AQUACIAT** unit with R-32 refrigerant can be equipped with a variable-speed pump with constant or variable water flow control to significantly reduce pumping energy costs.

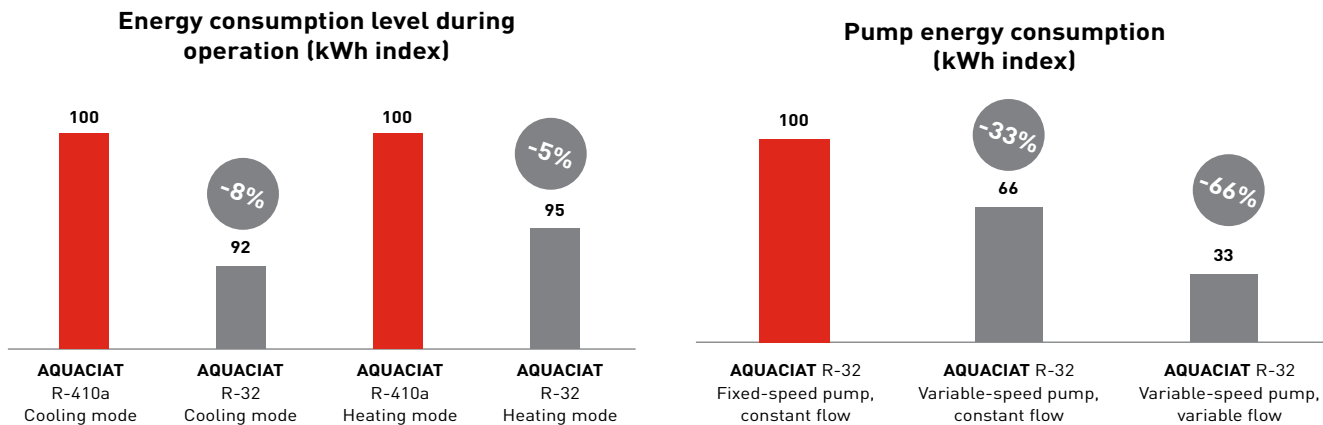

This performance is the result of the high-quality components used, which have all been rigorously selected:

- R-32 refrigerant with high energy performance,
- New generation of scroll compressors optimised for R-32 refrigerant
- Asymmetrical brazed-plate heat exchanger with extremely low water-side pressure drops enabling a reduction in pump electricity consumption
- Optional variable-speed pump enabling automatic adjustment of the rated water flow rate (disposal of the control valve), during operation and during unit shut down periods.

To conclude, the AQUACIAT unit with R-32 refrigerant and variable-speed pump greatly reduces the indirect environmental impact compared to the previous generation R-410A.

■ EcoPassport®

The PEP ecopassport® programme provides an international reference framework for procedures enabling manufacturers to report the environmental specifications of their products in the form of an environmental claim known as a Product Environmental Profile (PEP).

The PEP ecopassport® programme guarantees that PEPs are correctly drawn up, verified and reported in line with the requirements of the ISO 14025 and IEC/PAS 62545 standards.

The Life Cycle Analysis (LCA) PEP is the environmental identity card for an item of equipment which details the environmental impacts of the product during its life cycle according to eight mandatory indicators:

1. Global Warming Potential
2. Impact on the ozone layer
3. Acidification of soil and water
4. Eutrophication of water
5. Photochemical ozone creation
6. Abiotic resource depletion
7. Fresh water consumption
8. Total use of primary energy during the life cycle



Products with certified environmental profiles are used to support methods to assess building sustainability such as BREEAM, LEED. BREEAM, LEED gives additional recognition for materials with robust environmental product declaration types using manufacturer data.

CIAT is the first HVAC manufacturer to provide the PEP for liquid chillers and heat pumps including not only the 8 mandatory indicators, but all 27 indicators.

The **AQUACIAT** PEP can be downloaded from the PEP ecopassport® website: <http://www.pep-ecopassport.org/fr/>

AVAILABLE OPTIONS

Options	Description	Advantages	AQUACIAT LD	AQUACIAT ILD
Corrosion protection, traditional coils	Fins made of pre-treated aluminum by chemical conversion	Improved corrosion resistance, recommended for moderate marine and urban environments	No	•
Low-temperature brine solution	Low temperature chilled water production down to -8°C with ethylene or propylene glycol	Covers specific applications such as ice storage and industrial processes	•	According sizes
XtraFan	Unit equipped with specific variable-speed fans: XtraFans (See specific chapter for maximum available static pressure according to size), each fan equipped with a connection flange and flexible sleeves	Ducted fan discharge, optimised temperature control, based on the operating conditions and system characteristics	•	•
Return air connection frame	Unit equipped with a connection frame at the heat exchange coil inlet	Facilitates channelling of the air at the unit inlet.	•	•
Xtra Low Noise	Acoustic compressor enclosure and low-speed fans	Noise emission reduction at reduced fan speed	•	•
High ambient temperature	Unit equipped with a higher speed fan	Unit operating range extended to higher ambient temperatures	•	•
EC fans	Unit equipped with EC fans	Improves the unit's energy efficiency	•	•
Protection grilles	Metallic protection grilles	Coil protection against possible impact	•	•
Air filter and return air connection frame	Unit equipped with a connection frame at the heat exchange coil inlet and G2 efficiency washable filter in accordance with EN 779	Facilitates channelling of the air at the unit inlet and protects the air exchanger against pollution	•	•
Electronic starter per compressor	Electronic starter on each compressor	Reduced start-up current	•	•
All year round cooling operation down to -20°C	Fanspeed control via frequency converter	Stable unit operation when the outdoor air temperature is between -10°C and -20°C	•	•
Water exchanger frost protection	Electric heater on the water exchanger and the water piping	Water exchanger module frost protection between 0°C and -20°C outside air temperature	•	•
Hydronic module antifreeze protection	Electric heater on the hydronic module	Antifreeze protection of the hydronic module for outdoor temperatures down to -20°C	•	•
Exchanger and hydronic module antifreeze protection	Electric heaters on the water heat exchanger, water pipes, hydronic module, optional expansion tank and buffer tank	Water type heat exchanger and hydronic module frost protection down to an outdoor air temperature of -20°C	•	•
Partial heat recovery	Unit equipped with one desuperheater on each refrigerant circuit	Production of free high-temperature hot-water simultaneously with chilled water production (or hot water for heat pump)	•	•
Lead/Lag operation	Unit equipped with supplementary water outlet temperature sensor kit to be field installed allowing Lead/Lag operation of two units connected in parallel	Optimised operation of two units connected in parallel operation with operating time equalisation	•	•
Evaporator single HP pump	High pressure fixed-speed water pump, drain valve, air vent and pressure sensors. (optional expansion tank and built-in safety hydraulic components available)	Quick and easy installation (plug & play)	•	•
Evaporator dual HP pump	Dual high pressure fixed-speed water pump, pressure sensors.(optional expansion tank and built-in hydraulic safety components available)	Quick and easy installation (plug & play)	•	•
Variable-speed single HP pump	Single low pressure water pump, water filter, electronic water flow control, pressure sensors.Multiple variable water flow control options (optional expansion tank and built-in hydraulic safety components available)	Quick and easy installation (plug & play), significant pumping energy cost savings (up to 2/3), tighter water flow control.	•	•

• ALL MODELS

(1) Standard equipment on ILD version

Refer to the selection tool to find out which options are not compatible.

AVAILABLE OPTIONS

Options	Description	Advantages	AQUACIAT LD	AQUACIAT ILD
Variable-speed dual high pressure pump	Dual high pressure water pump with speed regulator, pressure sensors. Multiple water flow rate control options. For more details, refer to the dedicated section.	Quick and easy installation (plug & play), significant pumping energy cost savings (more than two-thirds), tighter water flow control, improved system reliability	•	•
Variable-speed single LP pump	Single low pressure water pump with speed regulator, pressure sensors. Multiple water flow rate control options. (optional expansion tank and built-in hydraulic safety components available)	Quick and easy installation (plug & play), significant pumping energy cost savings (up to 2/3), tighter water flow control.	•	•
Variable-speed dual LP pump	Evaporator hydronic module equipped with a variable-speed low pressure pump, a drain valve, an air vent and pressure sensors. For more details, refer to the dedicated section (expansion tank not included; option with built-in hydraulic safety components available)	Quick and easy installation (plug & play), significant pumping energy cost savings (up to 2/3), tighter water flow control.	•	•
Evaporator single LP pump	Single low pressure fixed-speed water pump, pressure sensors. (optional expansion tank and built-in hydraulic safety components available)	Quick and easy installation (plug & play)	•	•
Dual LP pump hydronic module	Dual low pressure water pump, water filter, pressure sensors. For more details, refer to the dedicated chapter (expansion tank not included; option with built-in hydraulic safety components)	Quick and easy installation (plug & play)	•	•
Heating Optimized	Specific configuration to optimized heating mode	Enlarge operating map in heating mode, and increase energetics performances (COP/ SCOP)	No	•
Lon gateway	Bidirectional communication board using LonTalk protocol	Connects the unit by communication bus to a centralised building management system	•	•
Bacnet over IP	Two-directional high-speed communication using BACnet protocol over Ethernet network (IP)	Easy and high-speed connection by Ethernet line to a building management system. Allows access to multiple unit parameters	•	•
Refrigerant leak detector	Unit equipped with refrigerant leak detector	Immediate customer notification of refrigerant losses to the atmosphere, allowing timely corrective actions	•	•
External boiler management	Control board factory-installed on the unit to control a boiler	Extended remote control capabilities to a boiler on/off command. Permits easy control of a basic heating system	No	•
Electric heaters management	Control board factory-installed on the unit with additional inputs/outputs in order to manage up to 4 external heating stages (electrical heaters...)	Extended remote control capabilities to up to 4 electrics heaters. Permits easy control of a basic heating system	No	•
Smart Grid Ready	Standardized and secured label for integration on the smart electrical networks (DE, AUT, CH).	Optimizing the energy efficiency of the installation and helping to reduce the carbon footprint	No	•
Input contact for Refrigerant leak detection	0-10 V signal to report any refrigerant leakage in the unit directly on the controller (the leak detector itself must be supplied by the customer)	Immediate customer notification of refrigerant losses to the atmosphere, allowing timely corrective actions	•	•
Compliance with Russian regulations	EAC certification	Compliance with Russian regulations	•	•
Insulation of the evap. in/out ref. lines	Thermal insulation of the evaporator entering/leaving refrigerant lines with flexible, UV resistant insulation	Prevents condensation on the evaporator entering/leaving refrigerant lines	•	•
MCHE anti-corrosion protection Protect2	Coating by conversion process which modifies the surface of the aluminium producing a coating that is integral to the coil. Complete immersion in a bath to ensure 100% coverage. Minimal heat transfer variation, salt spray resistance test for 4000 hours (ASTM B117) [or equivalent]	Protect2 Improved corrosion resistance of the MCHE coils by 2, recommended for use in moderately corrosive environments	•	No

• ALL MODELS

[1] Standard equipment on ILD version

Refer to the selection tool to find out which options are not compatible.

AVAILABLE OPTIONS

Options	Description	Advantages	AQUACIAT LD	AQUACIAT ILD
MCHE anti-corrosion protection Protect4	Extremely durable and flexible epoxy polymer coating applied on micro channel coils by electro coating process, final UV protective topcoat. Minimal heat transfer variation, tested 6000 hours constant neutral salt spray per ASTM B117 (or equivalent), superior impact resistance per ASTM D2794 (or equivalent)	Protect4 Improved corrosion resistance of the MCHE coils by 4, recommended for use in extremely corrosive environments	•	No
Evaporator screw connection sleeves (kit)	Evaporator inlet/outlet screw connection sleeves	Allows unit connection to a screw connector	•	•
Reinforced ECM filtration for fan VFD	Pump variable frequency drive compliant with IEC 61800-3 class C1	Allows unit installation in domestic residential environment by reducing electromagnetic interferences	•	•
Reinforced ECM filtration for pump VFD	Pump variable frequency drive compliant with IEC 61800-3 class C1	Allows unit installation in domestic residential environment by reducing electromagnetic interferences	•	•
Expansion tank	6 bar expansion tank integrated in the hydronic module (requires hydronic module option)	Easy and fast installation (plug & play), & protection of closed water systems from excessive pressure	•	•
Water buffer tank module	Integrate water buffer tank	Avoid short cycle on compressors and ensure a stable water in the loop	•	•
Water buffer tank module with 16,31,45kW electrical backup	Integrates a water buffer tank module with a 16,31,45kW auxiliary heater	The tank avoids short cycles on the compressors and ensures the water in the loop is stable. The auxiliary heater provides additional or backup heating in heating mode.	No	•
Anti-vibration mounts	Elastomer anti-vibration mounts to be placed under the unit (material classified as fire class B2 according to DIN 4102).	Isolate the unit from the building, prevent the transmission of vibrations and associated noise to the building. Must be used in conjunction with a flexible connection on the water side	•	•
Exchangers flexible coupling connection	Heat exchanger flexible connections, water side	Easy to install. Limits the transmission of vibrations to the water network	•	•
Exchanger water filter	Water filter	Prevents dust entering the water network	•	•
Dry cooler management, free cooling mode	Regulation and connections for a 09PE or 09VE free cooling Dry cooler unit equipped with a control box with FC option	Easy system management, control capacity extended to a Dry cooler used in free cooling mode	•	No
Installation or application process outside Europe	Specific management of option compatibility	Permits non-standard option compatibility for HVAC application in the EU	•	•
Compliance with Moroccan regulations	Specific regulatory documentation	Compliance with Moroccan regulations	•	•
Delivery with plastic tarp cover	Unit wrapped in a plastic cover and strapped onto a wooden pallet.	Protects against dust and external soiling of the unit during storage and transport.	•	•

• ALL MODELS

(1) Standard equipment on ILD version

Refer to the selection tool to find out which options are not compatible.



HYDRONIC MODULE

■ The "ALL-IN-ONE" solution

The PLUG & COOL solution offered by AQUACIAT

The hydronic module contains all the hydraulic circuit components needed for the system to operate correctly:

- Buffer tank with 19-mm insulation, 208-litre capacity (option).
- Expansion tank (option):
 - 12 litres, 18 litres or 35 litres, depending on the model (see table of technical characteristics)
- Wide choice of pumps:
 - Single or dual pumps with runtime balancing and backup.
 - Low-pressure pumps (ILD only).
 - High pressure pumps.
 - Fixed-speed or variable-speed pumps.
- Water temperature and pressure sensors.
- Water filter
- Relief valve
- Drain circuit
- Air bleed valve
- Antifreeze protection (optional)

The components in the hydraulic system are carefully selected and factory assembled and tested to make the installation of the units simple and economical.

This ensures conditioning times, implementation times and space requirements are kept to a minimum.

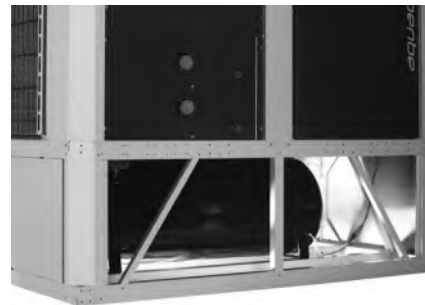



HYDRONIC MODULE

■ AQUACIAT hydronic module diagram

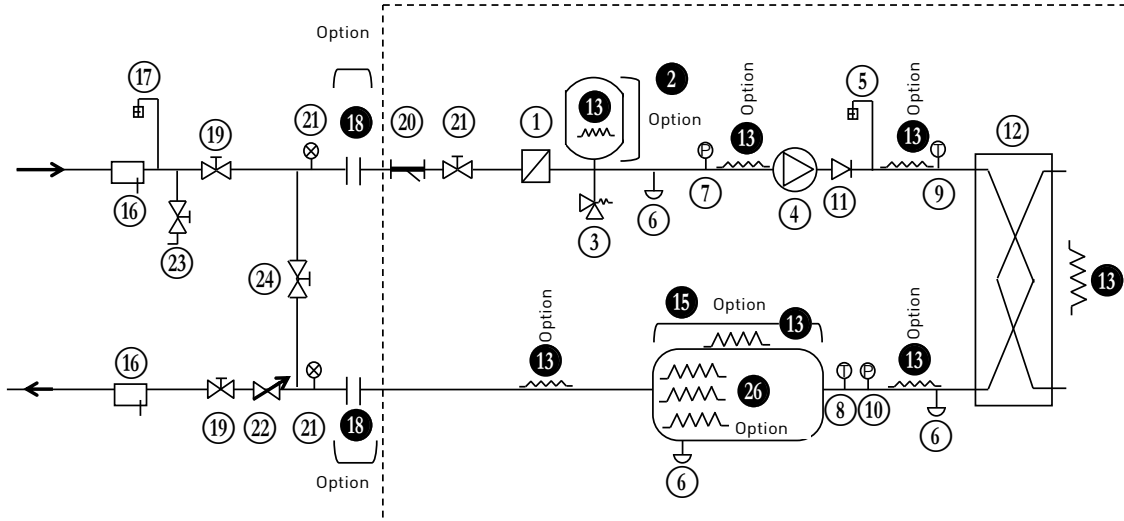

Key

Components of the unit and hydraulic module

- ① Screen filter (particle size of 1.2 mm)
- ② Expansion tank
- ③ Relief valve
- ④ Circulating pump (single or dual)
- ⑤ Air purge
- ⑥ Water drain tap
- ⑦ Pressure sensor
- Notes: Provides information on the pump inlet pressure**
- ⑧ Temperature sensor
- Notes: Provides information on the water type heat exchanger outlet temperature**
- ⑨ Temperature sensor
- Notes: Provides information on the water type heat exchanger inlet temperature**
- ⑩ Pressure sensor
- Notes: Provides information on the water type heat exchanger outlet pressure**
- ⑪ Checkvalve (for dual pumps)
- ⑫ Plate heat exchanger
- ⑬ Heater or heat trace cable for frost protection
- ⑭ Water type heat exchanger flow rate sensor
- ⑮ Buffer tank module
- Option

System components

- ⑬ Pocket
- ⑬ Air purge
- ⑬ Flexible connection
- ⑬ Shut-off valve
- ⑬ 800 µm screen filter (Option - mandatory in the case of a unit without hydronic module/included on version with hydronic module)
- ⑬ Pressure gauge
- ⑬ Water flow control valve

Note: Not required if hydronic module with variable-speed pump

- ⑬ Charge valve
- ⑬ Bypass valve for frost protection (if shut-off valves are closed (item 19) during winter)
- Hydronic module (unit with hydronic module option)
- ⑬ Auxiliary heaters in tank (option). The option includes a vent on the tank + a WTOT temperature sensor at the tank outlet.

Notes:

- The system must be protected against frost.
- The unit's hydronic module and the water type heat exchanger may be protected (factory-fitted option) against freezing using electric heaters and heat trace cables (13)
- The pressure sensors are assembled on connections without Schrader. Depressurise and drain the system before any work.

VARIABLE FLOW PUMP

■ Description

AQUACIAT may be equipped with one or two variable-speed pumps to save energy by adapting one pump's electrical power consumption to the hydraulic system's actual requirements, specifically in the case of oversized systems.

■ Simple to use

The "variable-speed pump" option is fully integrated and protected on the unit, which is installed outdoors to avoid the need for machine room work.

The assembly is factory-fitted and pre-set on the unit; it is therefore quick to install and reduces the cost of work, in particular because there is no water flow control valve on the unit's outlet.

The ability to adjust the water flow to your requirements means that the pump pressure can be adapted precisely to the actual pressure drop on the system when it is started up on-site.

■ Operating principle

Full load operating

A regulator, with a direct display of the flow rate and pressure on the Connect Touch screen, enables one pump (pump A in the example below) to be adapted, by lowering its pressure P_1 to the requirements of system P_2 , to obtain the optimal water flow rate setpoint. Electricity bills for the pump consumption are proportionally reduced, guaranteeing a return on investment (ROI) in just a few years, compared to the same fixed-speed pump equipped with a single flow rate adjustment valve.

Operation at partial load

Three partial operating modes are available:

1- Fixed speed

The control ensures the pump continuously runs at a constant speed, based on the capacity of the compressor(s). During compressor downtime periods, the Connect Touch "standby" function manages the electrical power consumed by the pump by reducing its speed to the minimum setting.

This provides energy savings of around 33%

2- Variable flow rate: Constant regulation of the pressure difference

The regulation system continuously controls the pump speed to guarantee a constant pressure difference. This solution is suitable for installations with two-way valves. This control mode is used to ensure a uniform supply in each hydraulic circuit to make sure that each terminal unit operates at a satisfactory pressure

3- Variable flow rate: Constant regulation of the temperature difference

The regulation maintains a constant temperature difference whatever the load rate of the unit by reducing the flow rate to the minimum acceptable limit. This control mode is suitable for most comfort applications.

This provides energy savings of around 66% for the pump in each of these last two operating modes

■ SOFT START

A soft start function prevents current surges during pump start-up to avoid disturbances in the electrical network, thereby limiting current draw in the building during peak periods and preventing hammering in the pipes.

■ STANDBY function

Lowering the speed when the compressors are on standby reduces the water flow rate to ensure the water loop is perfectly homogenised and the control temperature sensors are well irrigated. This reduces the pump's electricity consumption by around 80% during standby periods, which represents a significant proportion of the machine's normal operating time, in particular for air conditioning applications.

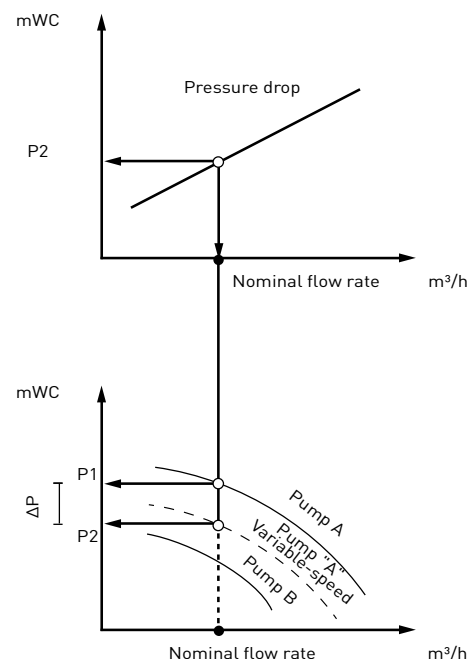

16, 31, 45 kW AUXILIARY HEATER MODULE (ILD 150R TO 300R)

■ General description

On sizes 150R to 300R, the CIAT auxiliary heater module is a simple and economical way of providing safe additional heating on a water loop in heating mode, particularly in heat pump mode when outdoor temperatures are very low.

This additional heating is especially designed for heating by heat pump, for the hotel and collective housing sectors, for example, or for some tertiary sector applications.

■ Electrical data

Rated electrical power	16 kW	31 kW	45 kW
kW power stages	8+8	8+8+15	15+15+15
Power supply	3-ph 50 Hz 400 V + Earth		
MAX rated current ⁽¹⁾	23,2A	44,9A	65,1A
Control circuit voltage	1-ph~50 Hz 24 V + Earth		
Number of stages possible	2	3	3
MAX temperature setpoint	+60°C		
MAX service pressure	4 bar		

(1) Warning: The current shown in the table above is to be added to the maximum nominal current of the ILD-auxiliary heater module. This value is essential for calculating the sizing of the power supply cable for the assembly.

■ Composition of the auxiliary heater module

Factory fitted with self-regulating frost protection, the auxiliary heater module is supplied within a single-unit housing similar to that of the reversible unit, which allows it to be installed and used outside during adverse weather conditions.

Depending on the user's requirements, it is available with 3 electrical power ratings: 16 kW, 31 kW or 45 kW.

■ Technical characteristics

Specially designed for **AQUACIAT** reversible **ILD 150R** to **300R** units, the auxiliary heater module is available as a fully factory-fitted and tested option.

It is built into the casing of the reversible unit, for which it also provides the power input from a single power terminal strip, whilst ensuring aesthetic unity on-site.

It is fully managed by the heat pump when operating in HEATING mode.

■ Equipment supplied as standard:

- Safety switch, connection strip
- Switches, thermal-magnetic circuit breakers
- Electric heater(s)
- Safety valve, automatic bleed device
- Electric frost protection with thermostat
- Painted casing for outdoor installation
- Water pipe thermal insulation

ENVIRONMENTAL RESPONSIBILITY

The **AQUACIAT** contributes to sustainable development via an environmentally responsible approach, aimed at balancing ecological and economic concerns. This enables it to meet the requirements of future European thermal regulations and to protect our environment for future generations.

The highly efficient performance it offers enables energy consumption to be greatly reduced, thereby reducing the unit's carbon footprint throughout its service life.

This performance is the result of the high quality components used, which have all been rigorously selected:

- New generation scroll compressors
- High energy efficiency R-32 fluid, low ODP (Ozone Depletion Potential) = 0, GWP (Global Warming Potential) = 675, no TFA (trifluoroacetic acid) impact
- MCHE micro-channel type coils for the cooling only version:
 - Energy efficiency increased by 10% compared to a conventional coil
 - 40% reduction in the refrigerant charge.
 - Reduction in the unit weight, reducing the environmental impact during transportation
 - Simplified end of life recycling thanks to the all-aluminium construction
- Asymmetrical brazed plate heat exchangers (BPHE)
- Reduction in the refrigerant charge compared with a tubular heat exchanger solution
- The asymmetrical technology enables a reduction in pressure drops on the water side, and an associated drop in electricity consumption.

Only 20% of a unit's impact on the ozone layer comes from the refrigerant (direct effect), with 80% coming from the CO₂ released into the atmosphere when the electricity required to power the unit is produced (indirect effect). With **AQUACIAT**, it's a win-win situation: its low refrigerant charge minimises the risk of emissions, and its low energy consumption limits its indirect impact.

The choice of technology used in the **AQUACIAT** range means that the TEWI, which covers the unit's environmental impact (both direct and indirect) throughout its service life, is greatly reduced.

INTEGRATION INTO THE MOST DEMANDING ENVIRONMENTS

The **AQUACIAT LD** has standard and optional equipment which enables it to be integrated into any one of a diverse range of environments.

In the micro-channel (MCH) coil, the rate of corrosion is less than in a conventional coil with copper tube and aluminium fins. Indeed, its all-aluminium design limits the galvanic couples in the coil, thereby providing increased corrosion resistance

- The Protect2 anti-corrosion post-treatment option doubles its resistance to corrosion. This treatment is applied by immersing the coil, ensuring complete protection as the aluminium surface undergoes a chemical change. This treatment is recommended for moderately corrosive environments
- The Protect4 anti-corrosion post-treatment option provides a fourfold increase in resistance to corrosion. An e-coating process is used to electro-coat the coil in polymer epoxy, and then a top layer of anti-UV protection is applied. This treatment is recommended for highly corrosive industrial and marine environments

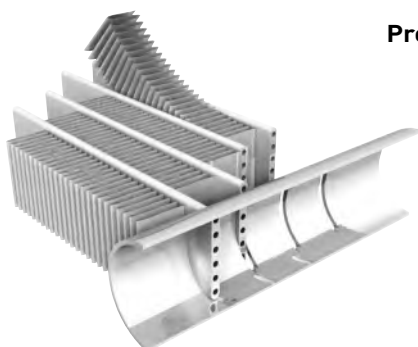

Protect2

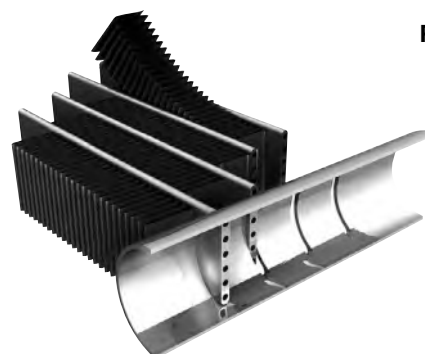

Protect4

XTRA FAN OPERATING PRESSURE VENTILATION

The **AQUACIAT** range can be equipped as an option with the XTRAFAN operating pressure ventilation.

■ Functions

The XTRAFAN offers a wide range of functions, making a whole host of flexible installation conditions possible, such as:

- The option of installation in a confined space, for example on a terrace surrounded by walls, where only an air supply with static pressure of between 100 and 200 pascals within a duct enables use without recirculation or mixing of air at the condenser intake,
- Installation in an urban area in which noise is a particular issue, where operation is only possible by adapting a sound trap to the supply air,
- A self-adjusting variable-speed function which allows "all-season" cooling, fully secured for industrial processes, including during harsh winter conditions with an external temperature of -20°C,
- The freedom to precisely adjust the ventilation speed on-site to what is "strictly necessary" to obtain the optimum air supply pressure, or the maximum acceptable noise level for the site on which the unit is located,
- An improvement in the energy efficiency and electrical consumption of the unit, in direct proportion to the load required by the installation

The performances (cooling capacity, heating capacity, power input, energy efficiency) depend on the rotation speed of the fans, and therefore on the required operating pressure in the duct.

The sound level at the duct outlet and the level radiated around the machine depend on the operating pressure.

Units with the Xtrafan option are equipped as standard with a supply air frame with a flexible sleeve on each fan to enable the discharge to be ducted.

A return air frame or return air frame plus filtration may be offered as an option on sizes 150R to 300R to duct and filter the intake air.

■ Precautions for installation

On-site installation of a reversible air-to-water packaged unit requires some measures to be taken. For example, the condensate draining must be specific to these units, particularly for when outdoor temperatures are very low.

During defrosting cycles, reversible units are liable to discharge a large amount of water onto the ground, which must be drained, as well as steam from the fan discharge which can damage the air discharge ducts. The ground supporting the unit must be perfectly watertight and capable of collecting and draining the defrosted water, including during freezing periods. It is recommended that the unit is raised by approximately 300 mm.

If an air discharge duct is installed on site, its weight must not be supported by the roof of the unit. Each fan must be connected independently.

Note: See detailed dimensional drawings for XtraFan option and return air frame.

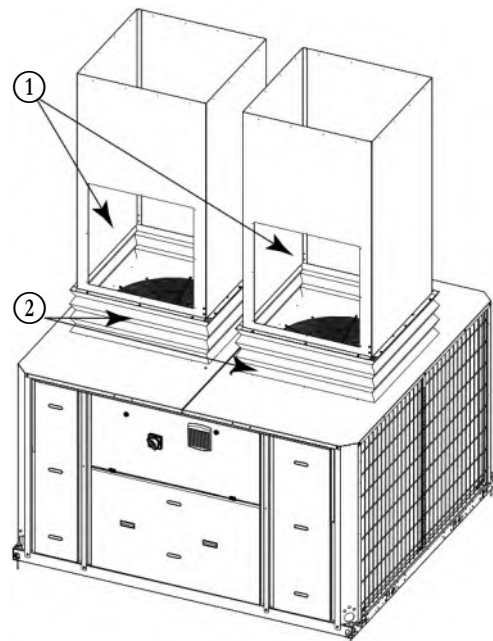

Unit with grille protection option

NOTE: The discharge lines must be ducted separately.

- ① Access hatches to the motor and fan (700 x 700 mm hatches) for each single and dual duct
- ② Connection boot or sleeve



AQUACIAT LD/ILD 150R-300R with XtraFan options + return air frame and filtration

INTELLIGENTLY DESIGNED ACOUSTICS

To comply with the various restrictions on integration, the **AQUACIAT** has two sound finish levels enabling it to be easily integrated into a number of zones without causing disruption to users or their neighbours.

■ Basic version

The distinguishing feature of the **AQUACIAT** range is its rigorous design incorporating "noiseless" assembly techniques to reduce vibrations and sources of noise:

- New generation scroll compressors with continuous scroll movement generating low vibration
- Compressor structure separated from the unit by anti-vibration mounts
- Pipes separated from the unit structure
- Fans made from a synthetic material, with aerodynamic blades offering an optimised profile. Optimised coil-fan combination, the result of many hours of study of the thermal and acoustic properties in our Research and Innovation Centre, to ensure a linear flow of air without turbulence, to limit noise to an acceptable acoustic spectrum.
- The Connect Touch controller automatically adjusts the fan air flow rate according to the outdoor air temperature and the unit's load rate which enables the sound level to be significantly reduced, particularly at night, mid-season, morning and evening, which totals more than 75% of the time the unit is used

■ Xtra Low Noise option

In this version, the compressors are housed in jackets and the fan rotation speed is reduced whilst ensuring the output and thermal performance remain optimised.

XTRA LOW NOISE



As low as -9 dB(A)

Thanks to the compressor enclosure

■ Night mode

The **AQUACIAT** has a Night Mode enabling the sound level to be limited at night or when the building is unoccupied (according to the user programming) by controlling the output and the fan rotation speed.

NIGHT MODE



Sound level reduction

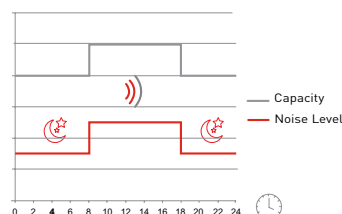

■ Acoustic signature

As important as the sound power level, the acoustic signature reflects the noise disturbance generated by the unit.

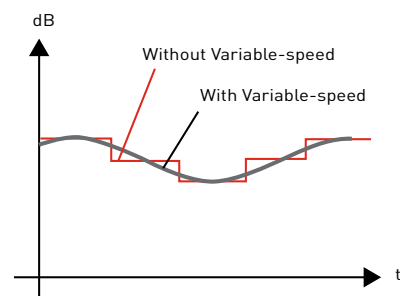
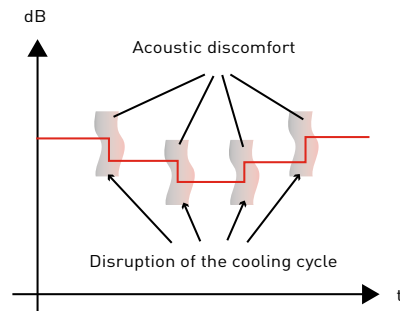

The **AQUACIAT** can be equipped as an option with a variable-speed motor, enabling the fan to start gradually (all-season operation).

It avoids the increases in noise linked to the on/off sequences, thereby improving the unit's acoustic signature.

Installing a variable-speed pump also reduces the noise level of the pumping function by adjusting the pump speed to the exact requirements. The soft start improves the signature and reduces nuisance noise.

With all these benefits and its two acoustic finish levels (Standard and Xtra Low Noise), the **AQUACIAT** can be integrated into any site, ensuring any constraints in terms of the sound environment can be met.

With all these benefits and a variety of acoustic finish levels, the **AQUACIAT** range can be integrated into any site, ensuring any constraints in terms of the sound environment can be met, while guaranteeing maximum comfort for users and their neighbours, guaranteeing peace and quiet for customers in the hotels market, and rest and recovery for those in hospital environments.





TECHNICAL CHARACTERISTICS - COOLING ONLY

AQUACIAT LD		150R	180R	200R	202R	240R	260R		
Standard unit									
Cooling Full load performances*	CA1	Nominal capacity	kW	41,7	47,3	52,9	56,1	63,6	71,2
		EER	kW/kW	2,95	2,94	2,93	2,97	2,89	2,90
	CA2	Nominal capacity	kW	54,6	62,7	69,4	74,3	84,6	93,0
		EER	kW/kW	3,60	3,60	3,51	3,61	3,63	3,49
Seasonal energy efficiency**	SEER_{12/7°C} Comfort low temp.		kWh/kWh	4,41	4,47	4,50	4,62	4,41	4,31
	ns cool _{12/7°C}		%	173	176	177	182	174	169
	SEER_{23/18°C} Comfort medium temp.		kWh/kWh	6,10	6,11	6,06	6,17	5,61	5,72
	SEPR_{12/7°C} Process high temp.		kWh/kWh	6,30	6,23	6,23	6,21	5,92	5,46
	SEPR_{-2/-8°C} Process medium temp.		kWh/kWh	3,59	3,65	3,79	3,89	3,65	3,61
Part Load integrated values	IPLV.SI	kW/kW	4,945	5,025	5,182	5,270	5,369	4,630	
Sound levels									
Standard unit and High outdoor temperature option									
Sound power ⁽¹⁾		dB(A)	81	82	83,5	83,5	89	89	
Sound pressure at 10 m ⁽²⁾		dB(A)	50	51	52	52	57	58	
Unit + Xtra Low Noise option									
Sound power ⁽¹⁾		dB(A)	78	79	80	80	80	80	
Sound pressure at 10 m ⁽²⁾		dB(A)	47	48	49	49	48	49	
Dimensions									
Length		mm	2109	2109	2109	2109	2109	2109	
Width		mm	1090	1090	1090	1090	1090	1090	
Height		mm	1330	1330	1330	1330	1330	1330	
Unit height (XtraFan option)		mm	1372	1372	1372	1372	1372	1372	
Unit height (optional buffer tank)		mm	1931	1931	1931	1931	1931	1931	
Unit height (XtraFan + buffer tank option)		mm	1973	1973	1973	1973	1973	1973	
Operating weight ⁽³⁾									
Standard unit		kg	408	409	428	428	435	446	
Unit + single high pressure pump option		kg	428	429	448	448	455	466	
Unit + dual high pressure pump option		kg	455	456	475	475	482	493	
Unit + single high pressure pump and buffer tank options		kg	779	781	800	800	807	817	
Unit + dual high pressure pump and buffer tank options		kg	806	808	827	827	834	844	

* In accordance with standard EN14511-3:2022.
 ** In accordance with EN14825:2022, average climatic conditions
 CA1 Cooling mode conditions: evaporator water inlet/outlet temperature 12°C/7°C, outdoor air temperature 35°C, evaporator fouling factor 0 m². k/W
 CA2 Cooling mode conditions: evaporator water inlet/outlet temperature 23°C/18°C, outdoor air temperature 35°C, evaporator fouling factor 0 m². k/W
ns cool_{12/7°C} & SEER_{12/7°C} **Values in bold comply with Ecodesign Regulation (EU) No. 2016/2281 for Comfort applications**
SEER_{23/18°C} **Values in bold comply with Ecodesign Regulation (EU) No. 2016/2281 for Comfort applications**
SEPR_{-2/-8°C} **Values in bold comply with Ecodesign Regulation (EU) No. 2015/1095 for HT applications**
 IPLV.SI Calculated as per standard AHRI 551-591 [SI]
 (1) in dB ref=10⁻¹² W, 'A' weighted. Declared dual-number noise emission values in accordance with ISO 4871 (with an associated uncertainty of +/-3 dB(A)). Measured in accordance with ISO 9614-1.
 (2) In dB ref 20 µPa, 'A' weighted. Declared dual-number noise emission values in accordance with ISO 4871 (with an associated uncertainty of +/-3 dB(A)). For information, calculated from the sound power Lw(A).
 (3) Values are guidelines only. Refer to the unit name plate.



Eurovent certified values

CARRIER participates in the ECP programme for LCP-HP Check ongoing validity of certificate: www.eurovent-certification.com



TECHNICAL CHARACTERISTICS - COOLING ONLY

AQUACIAT LD		150R	180R	200R	202R	240R	260R
Compressors		Hermetic Scroll 48,3 r/s					
Circuit A		2	2	2	2	2	2
Circuit B		-	-	-	-	-	-
No. of control stages		2	2	2	2	2	2
Refrigerant⁽³⁾		R32 / A2L / PRG=675 in accordance with AR4					
Circuit A	kg	3,72	3,92	4,15	4,60	4,70	4,87
	tCO ₂ e	2,5	2,6	2,8	3,1	3,2	3,3
Circuit B	kg	-	-	-	-	-	-
	tCO ₂ e	-	-	-	-	-	-
Oil charge		POE					
Circuit A	l	6,00	6,00	6,60	6,60	6,60	7,20
Circuit B	l	-	-	-	-	-	-
Capacity control		Connect'Touch					
Minimum capacity	%	50	50	50	50	50	50
PED category		III					
Condenser		All-aluminium micro-channel coils (MCHE)					
Fans		Axial with rotating impeller					
Quantity		1	1	1	1	1	1
Maximum total air flow	l/s	3882	3802	4058	3900	5484	5452
Maximum rotation speed	rps	12	12	12	12	18	18
Evaporator		Direct expansion brazed-plate heat exchanger					
Water volume	l	3,55	4	4,44	4,44	5,18	6,07
Max. water-side operating pressure without hydronic module	kPa	1000	1000	1000	1000	1000	1000
Hydronic module (option)		Pump, Victaulic screen filter, relief valve, water and air vent valve, pressure sensors					
Pump		Centrifugal pump, monocell, 48,3 r/s, low- or high pressure (as required), single or dual (as required)					
Expansion vessel volume (option) ⁽⁴⁾	l	18	18	18	18	18	18
Buffer tank volume (optional)	l	208	208	208	208	208	208
Max. water-side operating pressure with hydronic module	kPa	400	400	400	400	400	400
Water connections with or without hydronic module		Victaulic® type					
Connections	inches	2	2	2	2	2	2
External diameter	mm	60,3	60,3	60,3	60,3	60,3	60,3
Casing paint colour		Colour code RAL 7035 & 7024					

(3) Values are guidelines only. Refer to the unit name plate.

(4) When delivered, the standard pre-infiltration of the tank is not necessarily the optimal value of the system. To permit changing the water volume, change the inflation pressure to a pressure that is close to the static head of the system. Fill the system with water (purging the air) to a pressure value that is 10 to 20kPa higher than the pressure in the tank



TECHNICAL CHARACTERISTICS - COOLING ONLY

AQUACIAT LD		300R	360R	390R	450R	520R	600R		
Standard unit									
Cooling Full load performances*	CA1	Nominal capacity	kW	81,1	93,4	107	124	140	160
		EER	kW/kW	2,78	2,97	2,83	2,85	2,87	2,76
	CA2	Nominal capacity	kW	103	126	142	162	183	203
		EER	kW/kW	3,22	3,72	3,48	3,40	3,48	3,21
Seasonal energy efficiency**	SEER_{12/7°C} Comfort low temp.		kWh/kWh	4,24	4,38	4,51	4,57	4,46	4,37
	ns cool _{12/7°C}		%	167	172	177	180	176	172
	SEER_{23/18°C} Comfort medium temp.		kWh/kWh	5,46	5,54	5,78	5,73	5,61	5,34
	SEPR_{12/7°C} Process high temp.		kWh/kWh	5,21	5,45	5,19	5,24	5,37	5,15
	SEPR_{-2/-8°C} Process medium temp.		kWh/kWh	3,67	3,54	3,54	3,74	3,61	3,68
Part Load integrated values	IPLV.SI	kW/kW	4,630	4,904	4,953	4,997	4,707	4,680	
Sound levels									
Standard unit and High outdoor temperature option									
Sound power ⁽¹⁾		dB(A)	89	91,5	91,5	92	92	92	
Sound pressure at 10 m ⁽²⁾		dB(A)	57	60	60	60	60	60	
Unit + Xtra Low Noise option									
Sound power ⁽¹⁾		dB(A)	80	83	83	83	83	83	
Sound pressure at 10 m ⁽²⁾		dB(A)	48	51	51	52	51	51	
Dimensions									
Length		mm	2109	2275	2275	2275	2275	2275	
Width		mm	1090	2125	2125	2125	2125	2125	
Height		mm	1330	1330	1330	1330	1330	1330	
Unit height (XtraFan option)		mm	1372	1372	1372	1372	1372	1372	
Unit height (optional buffer tank)		mm	1931	1931	1931	1931	1931	1931	
Unit height (XtraFan + buffer tank option)		mm	1973	1973	1973	1973	1973	1973	
Operating weight ⁽³⁾									
Standard unit		kg	454	672	734	743	861	877	
Unit + single high pressure pump option		kg	474	692	754	768	886	902	
Unit + dual high pressure pump option		kg	501	719	781	790	908	924	
Unit + single high pressure pump and buffer tank options		kg	825	1110	1172	1186	1304	1320	
Unit + dual high pressure pump and buffer tank options		kg	852	1137	1199	1208	1326	1342	

* In accordance with standard EN14511-3:2022.
 ** In accordance with EN14825:2022, average climatic conditions
 CA1 Cooling mode conditions: evaporator water inlet/outlet temperature 12°C/7°C, outdoor air temperature 35°C, evaporator fouling factor 0 m². k/W
 CA2 Cooling mode conditions: evaporator water inlet/outlet temperature 23°C/18 °C, outdoor air temperature 35°C, evaporator fouling factor 0 m². k/W
ns cool_{12/7°C} & SEER_{12/7°C}
SEER_{23/18 °C}
SEPR_{-2/-8°C}
 IPLV.SI
 (1) Values in bold comply with Ecodesign Regulation (EU) No. 2016/2281 for Comfort applications
 Values in bold comply with Ecodesign Regulation (EU) No. 2016/2281 for Comfort applications
 Values in bold comply with Ecodesign Regulation (EU) No. 2015/1095 for HT applications
 Calculated as per standard AHRI 551-591 (SI)
 in dB ref=10⁻¹²W, 'A' weighted. Declared dual-number noise emission values in accordance with ISO 4871 (with an associated uncertainty of +/-3 dB(A)). Measured in accordance with ISO 9614-1.
 (2) In dB ref 20 µPa, 'A' weighted. Declared dual-number noise emission values in accordance with ISO 4871 (with an associated uncertainty of +/-3 dB(A)). For information, calculated from the sound power Lw(A).
 (3) Values are guidelines only. Refer to the unit name plate.



Eurovent certified values

CARRIER participates in the ECP programme for LCP-HP Check ongoing validity of certificate: www.eurovent-certification.com



TECHNICAL CHARACTERISTICS - COOLING ONLY

AQUACIAT LD		300R	360R	390R	450R	520R	600R
Compressors		Hermetic Scroll 48,3 r/s					
Circuit A		2	2	3	3	2	2
Circuit B		-	-	-	-	2	2
No. of control stages		2	2	3	3	4	4
Refrigerant⁽³⁾		R32 / A2L / PRG=675 in accordance with AR4					
Circuit A	kg	4,84	7,75	8,40	9,00	5,00	5,07
	tCO ₂ e	3,3	5,2	5,7	6,1	3,4	3,4
Circuit B	kg	-	-	-	-	5,00	5,07
	tCO ₂ e	-	-	-	-	3,4	3,4
Oil charge		POE					
Circuit A	l	7,20	7,20	10,80	10,80	7,20	7,20
Circuit B	l	-	-	-	-	7,20	7,20
Capacity control		Connect'Touch					
Minimum capacity	%	50	50	33	33	25	25
PED category		III					
Condenser		All-aluminium micro-channel coils (MCHE)					
Fans		Axial with rotating impeller					
Quantity		1	2	2	2	2	2
Maximum total air flow	l/s	5414	10568	10512	10974	10904	10827
Maximum rotation speed	rps	18	18	18	18	18	18
Evaporator		Direct expansion brazed-plate heat exchanger					
Water volume	l	6,96	7,4	8,44	9,92	12,69	14,31
Max. water-side operating pressure without hydronic module	kPa	1000	1000	1000	1000	1000	1000
Hydronic module (option)		Pump, Victaulic screen filter, relief valve, water and air vent valve, pressure sensors					
Pump		Centrifugal pump, monocell, 48,3 r/s, low- or high pressure (as required), single or dual (as required)					
Expansion vessel volume (option) ⁽⁴⁾	l	18	35	35	35	35	35
Buffer tank volume (optional)	l	208	208	208	208	208	208
Max. water-side operating pressure with hydronic module	kPa	400	400	400	400	400	400
Water connections with or without hydronic module		Victaulic® type					
Connections	inches	2	2	2	2	2	2
External diameter	mm	60,3	60,3	60,3	60,3	60,3	60,3
Casing paint colour		Colour code RAL 7035 & 7024					

(3) Values are guidelines only. Refer to the unit name plate.

(4) When delivered, the standard pre-infiltration of the tank is not necessarily the optimal value of the system. To permit changing the water volume, change the inflation pressure to a pressure that is close to the static head of the system. Fill the system with water (purging the air) to a pressure value that is 10 to 20kPa higher than the pressure in the tank



TECHNICAL CHARACTERISTICS - REVERSIBLE HEAT PUMP

AQUACIAT ILD		150R	180R	200R	240R	260R	300R
--------------	--	------	------	------	------	------	------

Standard unit

Heating Full load performances*	HA1	Nominal capacity	kW	44,1	47,9	54,3	61,6	68,2	61,8
		COP	kW/kW	3,91	3,97	3,89	3,80	3,81	3,03
	HA2	Nominal capacity	kW	42,7	47,0	53,5	59,5	67,2	75,7
		COP	kW/kW	3,07	3,16	3,12	3,01	3,08	3,01
Seasonal energy efficiency**	HA1	SCOP _{30/35°C}	kWh/kWh	3,82	3,78	3,81	3,58	3,67	3,65
		ns heat _{30/35°C}	%	150	148	149	140	144	143
		P _{rated}	kW	32	34	36	43	50	55
Cooling Full load performances*	CA1	Nominal capacity	kW	41,0	43,1	50,3	60,2	65,2	74,3
		EER	kW/kW	2,89	2,69	2,66	2,97	2,90	2,66
Seasonal energy efficiency**		SEER _{12/7°C} Comfort low temp.	kWh/kWh	4,19	4,23	4,18	4,34	4,25	4,03
		SEPR _{12/7°C} Process high temp.	kWh/kWh	6,08	5,93	5,69	6,13	5,87	5,39

Unit with Heating Optimized option

Heating Full load performances*	HA1	Nominal capacity	kW	44,4	48,2	54,6	62,2	68,9	62,3
		COP	kW/kW	4,02	4,09	3,99	3,93	3,92	3,15
	HA2	Nominal capacity	kW	43,1	47,4	53,9	60,2	67,9	76,3
		COP	kW/kW	3,18	3,29	3,23	3,15	3,20	3,17
Seasonal energy efficiency**	HA1	SCOP _{30/35°C}	kWh/kWh	3,97	3,93	3,96	3,78	3,88	3,89
		ns heat _{30/35°C}	%	156	154	155	148	152	153
		P _{rated}	kW	32	34	36	43	50	55
Cooling Full load performances*	CA1	Nominal capacity	kW	38,9	41,1	48,1	57,5	62,7	71,8
		EER	kW/kW	2,75	2,57	2,56	2,85	2,80	2,59
Seasonal energy efficiency**		SEER _{12/7°C} Comfort low temp.	kWh/kWh	3,95	4,00	3,98	4,15	4,06	3,89
		SEPR _{12/7°C} Process high temp.	kWh/kWh	5,68	5,56	5,39	5,79	5,56	5,17

Sound levels
Standard unit and High outdoor temperature option

Sound power ⁽¹⁾	dB(A)	82,0	83,0	84,0	89,0	89,5	89,5
Sound pressure at 10 m ⁽²⁾	dB(A)	50,0	51,0	52,5	57,5	58,0	58,0
Sound power ECODESIGN SCOPC conditions	dB(A)	77,0	79,0	83,0	83,5	83,5	81,0

Unit + Xtra Low Noise option

Sound power ⁽¹⁾	dB(A)	78,5	79,0	80,5	80,5	80,5	80,5
Sound pressure at 10 m ⁽²⁾	dB(A)	47,0	47,5	49,0	49,0	48,5	49,0
Sound power ECODESIGN SCOPC conditions	dB(A)	74,5	77,0	80,0	81,0	81,0	79,0

* In accordance with standard EN14511-3:2022.

** In accordance with EN14825:2022, average climatic conditions

HA1 Heating mode conditions: Water type heat exchanger water inlet/outlet temperature 30°C/35°C, outdoor air temperature tdb/twb = 7°C db/6°C wb, evaporator fouling factor 0 m². k/W

HA2 Heating mode conditions: Water type heat exchanger water inlet/outlet temperature 40°C/45°C, outdoor air temperature tdb/twb = 7°C db/6°C wb, evaporator fouling factor 0 m². k/W

CA1 Cooling mode conditions: evaporator water inlet/outlet temperature 12°C/7°C, outdoor air temperature 35°C, evaporator fouling factor 0 m². k/W

ns heat_{30/35°C} & SCOP_{30/35°C} Values in bold comply with Ecodesign Regulation (EU) No. 813/2013 for Heating applications

SEER_{12/7°C} & SEPR_{12/7°C} Applicable Ecodesign regulation (EU) No. 2016/2281

[1] in dB ref=10⁻¹² W, 'A' weighted. Declared dual-number noise emission values in accordance with ISO 4871 (with an associated uncertainty of +/-3 dB(A)). Measured in accordance with ISO 9614-1.

[2] in dB ref 20 µPa, 'A' weighted. Declared dual-number noise emission values in accordance with ISO 4871 (with an associated uncertainty of +/-3 dB(A)). For information, calculated from the sound power Lw(A).



Eurovent certified values

CARRIER participates in the ECP programme for LCP-HP Check ongoing validity of certificate: www.eurovent-certification.com



TECHNICAL CHARACTERISTICS - REVERSIBLE HEAT PUMP

AQUACIAT ILD		150R	180R	200R	240R	260R	300R
Dimensions							
Standard unit							
Length	mm	2109	2109	2109	2109	2109	2109
Width	mm	1090	1090	1090	1090	1090	1090
Height	mm	1330	1330	1330	1330	1330	1330
Unit height (XtraFan option)	mm	1372	1372	1372	1372	1372	1372
Unit height (optional buffer tank)	mm	1931	1931	1931	1931	1931	1931
Unit height (XtraFan + buffer tank option)	mm	1973	1973	1973	1973	1973	1973
Operating weight ⁽³⁾							
Standard unit		444	446	469	496	506	515
Unit + single high pressure pump option	kg	464	466	489	516	526	535
Unit + dual high pressure pump option	kg	491	493	516	543	553	562
Unit + single high pressure pump and buffer tank options	kg	816	818	841	868	877	887
Unit + dual high pressure pump and buffer tank options	kg	843	845	868	895	904	914
Compressors		Hermetic Scroll 48,3 r/s					
Circuit A		2	2	2	2	2	2
Circuit B		-	-	-	-	-	-
No. of control stages		2	2	2	2	2	2
Refrigerant⁽³⁾		R-32 / A2L/ PRP= 675 in accordance with AR4					
Circuit A	kg	7,30	7,30	7,80	8,70	8,95	9,20
	tCO ₂ e	4,9	4,9	5,3	5,9	6,0	6,2
Circuit B	kg	-	-	-	-	-	-
	tCO ₂ e	-	-	-	-	-	-
Oil charge		POE					
Circuit A	l	6	6	7	7	7	7
Circuit B	l	-	-	-	-	-	-
Capacity control		Connect'Touch					
Minimum capacity	%	50	50	50	50	50	50
PED category		III					
Condenser		Grooved copper tubes and aluminium fins					
Fans		Axial with rotating impeller					
Standard unit							
Quantity		1	1	1	1	1	1
Maximum total air flow	l/s	4034	4034	4034	5613	5613	5613
Maximum rotation speed	rps	12	12	12	16	16	16
Evaporator		Direct expansion brazed-plate heat exchanger					
Water volume	l	4	4	4	5	6	7
Max. water-side operating pressure without hydronic module	kPa	1000	1000	1000	1000	1000	1000
Hydronic module (option)		Pump, Victaulic screen filter, relief valve, water and air vent valve, pressure sensors					
Pump		Centrifugal pump, monocell, 48,3 r/s, low- or high pressure (as required), single or dual (as required)					
Expansion tank volume (Option)	l	12	12	12	12	12	12
Buffer tank volume (optional)	l	208	208	208	208	208	208
Max. water-side operating pressure with hydronic module	kPa	400	400	400	400	400	400
Water connections with or without hydronic module		Victaulic® type					
Connections	inches	2	2	2	2	2	2
External diameter	mm	60	60	60	60	60	60
Casing paint colour		Colour code RAL 7035 & 7024					

(3) Values are guidelines only. Refer to the unit name plate.



TECHNICAL CHARACTERISTICS - REVERSIBLE HEAT PUMP

AQUACIAT ILD			360R	390R	450R	520R	600R	
Standard unit								
Heating Full load performances*	HA1	Nominal capacity	kW	93,3	107	119	137	123
		COP	kW/kW	3,80	3,80	3,80	3,80	3,03
	HA2	Nominal capacity	kW	91,7	105	118	135	150
		COP	kW/kW	3,10	3,09	3,09	3,08	3,00
Seasonal energy efficiency**	HA1	SCOP _{30/35°C}	kWh/kWh	3,61	3,56	3,79	3,76	3,78
		ns heat _{30/35°C}	%	141	139	149	147	148
		P _{rated}	kW	60	68	87	100	109
Cooling Full load performances*	CA1	Nominal capacity	kW	87,0	99,9	114	132	147
		EER	kW/kW	2,88	2,84	2,93	2,85	2,66
	Seasonal energy efficiency**	SEER _{12/7°C} Comfort low temp.	kWh/kWh	4,48	4,86	4,88	4,20	4,09
		SEPR _{12/7°C} Process high temp.	kWh/kWh	5,82	5,82	5,89	5,48	5,24
Unit with Heating Optimized option								
Heating Full load performances*	HA1	Nominal capacity	kW	94,4	108	120	137	123
		COP	kW/kW	3,94	3,87	3,88	3,90	3,13
	HA2	Nominal capacity	kW	92,9	106	119	136	151
		COP	kW/kW	3,25	3,18	3,18	3,20	3,15
Seasonal energy efficiency**	HA1	SCOP _{30/35°C}	kWh/kWh	3,77	3,71	3,95	3,98	4,00
		ns heat _{30/35°C}	%	148	145	155	156	157
		P _{rated}	kW	60	69	88	100	109
Cooling Full load performances*	CA1	Nominal capacity	kW	83,4	96,0	110	127	143
		EER	kW/kW	2,77	2,74	2,83	2,76	2,58
	Seasonal energy efficiency**	SEER _{12/7°C} Comfort low temp.	kWh/kWh	4,29	4,63	4,66	4,10	4,02
		SEPR _{12/7°C} Process high temp.	kWh/kWh	5,52	5,49	5,58	5,33	5,16
Sound levels								
Standard unit and High outdoor temperature option								
Sound power ⁽¹⁾			dB(A)	92,0	92,0	92,0	92,5	92,0
Sound pressure at 10 m ⁽²⁾			dB(A)	60,5	60,5	60,5	61,0	60,5
Sound power ECODESIGN SCOPC conditions			dB(A)	84,5	82,0	82,5	90,0	90,0
Unit + Xtra Low Noise option								
Sound power ⁽¹⁾			dB(A)	83,5	83,5	83,5	83,5	83,5
Sound pressure at 10 m ⁽²⁾			dB(A)	52,0	52,0	51,5	52,0	51,5
Sound power ECODESIGN SCOPC conditions			dB(A)	82,0	80,0	81,0	86,0	85,0

* In accordance with standard EN14511-3:2022.
 ** In accordance with EN14825:2022, average climatic conditions
 HA1 Heating mode conditions: Water type heat exchanger water inlet/outlet temperature 30°C/35°C, outdoor air temperature tdb/twb = 7°C db/6°C wb, evaporator fouling factor 0 m². k/W
 HA2 Heating mode conditions: Water type heat exchanger water inlet/outlet temperature 40°C/45°C, outdoor air temperature tdb/twb = 7°C db/6°C wb, evaporator fouling factor 0 m². k/W
 CA1 Cooling mode conditions: evaporator water inlet/outlet temperature 12°C/7°C, outdoor air temperature 35°C, evaporator fouling factor 0 m². k/W
ns heat_{30/35°C} & SCOP_{30/35°C} Values in bold comply with Ecodesign Regulation (EU) No. 813/2013 for Heating applications
SEER_{12/7°C} & SEPR_{12/7°C} Applicable Ecodesign regulation (EU) No. 2016/2281
 (1) in dB ref=10⁻¹² W, 'A' weighted. Declared dual-number noise emission values in accordance with ISO 4871 (with an associated uncertainty of +/-3 dB(A)). Measured in accordance with ISO 9614-1.
 (2) In dB ref 20 µPa, 'A' weighted. Declared dual-number noise emission values in accordance with ISO 4871 (with an associated uncertainty of +/-3 dB(A)). For information, calculated from the sound power Lw(A).



Eurovent certified values

CARRIER participates in the ECP programme for LCP-HP Check ongoing validity of certificate: www.eurovent-certification.com



TECHNICAL CHARACTERISTICS - REVERSIBLE HEAT PUMP

AQUACIAT ILD		360R	390R	450R	520R	600R
Dimensions						
Standard unit						
Length	mm	2275	2275	2275	2275	2275
Width	mm	2125	2125	2125	2125	2125
Height	mm	1330	1330	1330	1330	1330
Unit height (XtraFan option)	mm	1372	1372	1372	1372	1372
Unit height (optional buffer tank)	mm	1931	1931	1931	1931	1931
Unit height (XtraFan + buffer tank option)	mm	1973	1973	1973	1973	1973
Operating weight ⁽³⁾						
Standard unit						
Unit + single high pressure pump option	kg	779	838	891	1021	1025
Unit + dual high pressure pump option	kg	805	864	923	1054	1058
Unit + single high pressure pump and buffer tank options	kg	1197	1256	1309	1439	1443
Unit + dual high pressure pump and buffer tank options	kg	1223	1282	1341	1472	1476
Compressors						
Hermetic Scroll 48,3 r/s						
Circuit A		2	3	3	2	2
Circuit B		-	-	-	2	2
No. of control stages		2	3	3	4	4
Refrigerant⁽³⁾						
R-32 / A2L/ PRP= 675 in accordance with AR4						
Circuit A	kg	15,20	15,70	19,63	8,95	9,15
	tCO ₂ e	10,3	10,6	13,3	6,0	6,2
Circuit B	kg	-	-	-	8,95	9,15
	tCO ₂ e	-	-	-	6,0	6,2
Oil charge						
Circuit A	l	7	11	11	7	7
Circuit B	l	-	-	-	7	7
Capacity control						
Connect' Touch						
Minimum capacity	%	50	33	33	25	25
PED category						
III						
Condenser						
Grooved copper tubes and aluminium fins						
Fans						
Axial with rotating impeller						
Standard unit						
Quantity		2	2	2	2	2
Maximum total air flow	l/s	10904	10904	10904	11226	11226
Maximum rotation speed	rps	16	16	16	16	16
Evaporator						
Direct expansion brazed-plate heat exchanger						
Water volume	l	7	8	10	13	14
Max. water-side operating pressure without hydronic module	kPa	1000	1000	1000	1000	1000
Hydronic module (option)						
Pump, Victaulic screen filter, relief valve, water and air vent valve, pressure sensors						
Pump		Centrifugal pump, monocell, 48,3 r/s, low- or high pressure (as required), single or dual (as required)				
Expansion vessel volume (option) ⁽⁴⁾	l	12	35	35	35	35
Buffer tank volume (optional)	l	208	208	208	208	208
Max. water-side operating pressure with hydronic module	kPa	400	400	400	400	400
Water connections with or without hydronic module						
Victaulic® type						
Connections	inches	2	2	2	2	2
External diameter	mm	60	60	60	60	60
Casing paint colour						
Colour code RAL 7035 & 7024						

(3) Values are guidelines only. Refer to the unit name plate.

(4) When delivered, the standard pre-infiltration of the tank is not necessarily the optimal value of the system. To permit changing the water volume, change the inflation pressure to a pressure that is close to the static head of the system. Fill the system with water (purging the air) to a pressure value that is 10 to 20kPa higher than the pressure in the tank

ELECTRICAL SPECIFICATIONS

AQUACIAT LD/ILD	150R	180R	200R	202R	240R	260R	300R	360R	390R	450R	520R	600R		
Power circuit supply														
Nominal voltage	V-ph-Hz		400-3-50											
Voltage range	V		360-440											
Control circuit supply														
24 V via internal transformer														
Maximum operating input power^{(1) or (2)}														
Circuit A&B	kW		19	21	24	24	28	31	36	41	48	55	63	71
Power factor at maximum power^{(1) or (2)}														
Displacement Power Factor (Cos Phi), standard unit			0,81	0,82	0,82	0,82	0,84	0,84	0,85	0,82	0,84	0,85	0,84	0,85
Nominal unit current draw⁽⁴⁾														
Standard unit	A		26	29	35	35	36	46	52	59	71	81	91	104
Maximum operating current draw (Un)^{(1) or (2)}														
Standard unit	A		34	37	42	42	48	54	60	72	84	93	108	121
Maximum current (Un-10%)^{(1) or (2)}														
Standard unit	A		37	39	44	44	51	58	65	77	89	99	115	129
Maximum start-up current (Un) ^{(2) + (3)}														
Standard unit	A		116	118	165	165	169	177	191	238	206	223	231	251

(1) Values at the unit's permanent maximum operating condition (as shown on the unit's nameplate).

(2) Values at the unit's maximum operating condition (as shown on the unit's nameplate).

(3) Maximum operating current of the smallest compressor(s) + fan current + locked rotor current of the largest compressor.

(4) Standardised EUROVENT conditions, water-cooled exchanger water inlet/outlet = 12°C/7°C, outdoor air temperature = 35°C.

■ Short circuit current withstand capability (TN system⁽¹⁾)

AQUACIAT LD/ILD	150R	180R	200R	202R	240R	260R	300R	360R	390R	450R	520R	600R		
Rated short-circuit withstand currents														
Short time (1s) assigned current - I _{cw}	kA eff		3,36	3,36	3,36	3,36	3,36	3,36	5,62	5,62	5,62	5,62	5,62	5,62
Allowable peak assigned current - I _{pk}	kA pk		20	20	20	20	20	20	15	20	20	15	20	15
Value with upstream protection														
Conditional short circuit assigned current I _{cc}	kA eff		40	40	40	40	40	40	40	40	40	30	30	30
Associated protection	Circuit breaker/Schneider													
Associated protection	NS 100H	NS 100H	NS 100H	NS 100H	NS 100H	NS 100H	NS 100H	NS 100H	NS 100H	NS 160H	NS 160H	NS 250H	NS 250H	NS 250H

(1) If another current limitation protection device is used, its time-current and thermal constraint (I²t) trip characteristics must be at least equivalent to those of the recommended protection.

Note: The short-circuit stability current values given above are suitable for the TN system.



PARTIAL RECOVERY WITH DESUPERHEATER

The **AQUACIAT** range may be equipped as an option with an energy recovery function using a desuperheater. Heat from gases released by the compressors is recovered directly by a type of heat exchanger called a desuperheater located on the unit to produce free, additional hot water.

This optional configuration requires assembly in our factories and is by order only

■ Refrigerant circuit schematic diagram

This refrigeration diagram illustrates a unit with a desuperheater on each refrigerating circuit. For heat recovery to be possible, the unit must be operating. For the same cooling capacity, the desuperheater provides a source of free hot water and lowers the unit's electrical power consumption.

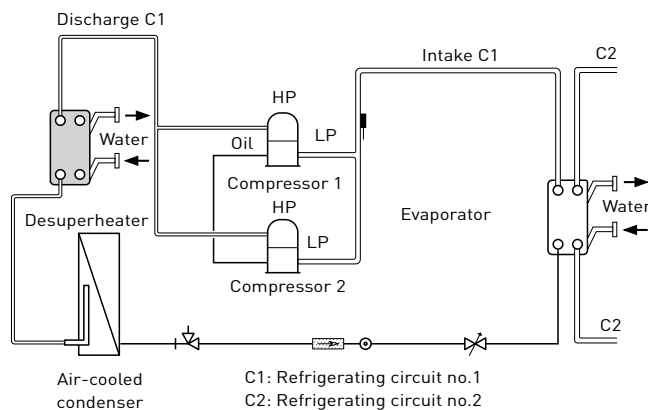

■ Hydraulic connections: configuration and precautions

The hydraulic supply for each desuperheater is delivered in parallel. In order to ensure that the unit can start and operate under the correct conditions, the desuperheater circuit water loop must be as short as possible and be able to increase quickly in temperature. The minimum desuperheater water inlet temperature must be 25°C. It may require the use of a three-way valve with its controller and a sensor controlling the minimum water inlet temperature.

Note:

The water loop for the desuperheater circuit must include an expansion tank and a valve. Special attention should be paid when selecting the expansion tank as the recovery hydraulic circuit can reach 120°C if the pump is turned off or if no hot water is consumed.

■ Operating limits

LD/ILD units

Desuperheater	Minimum	Maximum
Entering water temperature at start-up °C	30 ⁽¹⁾	75
Water outlet temperature during operation °C	45	80
Water inlet temperature on shut-down °C	3	75

Note: Do not exceed the maximum operating temperature.

(1) The water inlet temperature at start-up must not be lower than 30°C. On lower temperature installations, a 3-way valve is required until the desuperheater water outlet reaches 45°C.



PARTIAL RECOVERY WITH DESUPERHEATER

■ Technical characteristics

AQUACIAT LD		150R	180R	200R	202R	240R	260R	300R	360R	390R	450R	520R	600R
Desuperheater in circuits A/B		Brazed-plate heat exchanger											
Water volume circuits A/B	l	0,49	0,49	0,49	0,49	0,49	0,65	0,65	0,86	0,86	0,86	0,65	0,65
Maximum operating pressure, water side	kPa	1000	1000	1000	1000	1000	1000	1000	1000	1000	1000	1000	1000
Water connections		Victaulic											
Connection	in	1	1	1	1	1	1	1	1	1	1	1	1
External diameter	mm	42	42	42	42	42	42	42	42	42	42	42	42
Operating weight ⁽¹⁾													
Standard unit	kg	420	421	440	440	447	458	466	695	758	768	893	909
Unit + single high pressure pump and desuperheater option	kg	440	442	460	461	468	478	487	715	778	793	918	934
Unit + dual high pressure pump and desuperheater option	kg	467	469	487	488	495	505	514	742	805	825	951	967
Unit + single high pressure pump, buffer tank and desuperheater options	kg	792	793	812	813	819	830	838	1133	1196	1211	1336	1352
Unit + dual high pressure pump and buffer tank and desuperheater options	kg	819	820	839	839	846	857	865	1160	1223	1243	1369	1385

(1) Weights are guidelines only. Refer to the unit name plate.

AQUACIAT ILD		150R	180R	200R	240R	260R	300R	360R	390R	450R	520R	600R
Desuperheater in circuits A/B		Brazed-plate heat exchanger										
Water volume circuits A/B	l	0,49	0,49	0,49	0,49	0,65	0,65	0,86	0,86	0,86	0,65	0,65
Maximum operating pressure, water side	kPa	1000	1000	1000	1000	1000	1000	1000	1000	1000	1000	1000
Water connections		Victaulic										
Connection	in	1	1	1	1	1	1	1	1	1	1	1
External diameter	mm	42	42	42	42	42	42	42	42	42	42	42
Operating weight ⁽¹⁾												
Standard unit	kg	456	458	481	508	518	528	782	842	890	1022	1026
Unit + single high pressure pump and desuperheater option	kg	476	478	501	528	539	548	802	862	915	1047	1051
Unit + dual high pressure pump and desuperheater option	kg	503	505	528	555	566	575	828	888	947	1080	1084
Unit + single high pressure pump, buffer tank and desuperheater options	kg	828	830	853	880	890	900	1220	1280	1333	1465	1469
Unit + dual high pressure pump and buffer tank and desuperheater options	kg	855	857	880	907	917	927	1246	1306	1365	1498	1502

(1) Values are guidelines only. Refer to the unit name plate.

SOUND LEVELS

Standard unit/Unit with High outdoor temperature option

■ Sound power level (LW)

AQUACIAT LD Standard unit	Power level spectrum ⁽¹⁾									Global sound power level ⁽²⁾	
		63 Hz	125 Hz	250 Hz	500 Hz	1 kHz	2 kHz	4 kHz	8 kHz		
150R	dB	75	77	79	78	78	72	66	70	dB(A)	81,5
180R	dB	75	78	79	78	79	72	65	70	dB(A)	82,0
200R	dB	74	76	78	78	81	74	66	70	dB(A)	83,5
202R	dB	74	76	78	78	81	74	66	70	dB(A)	83,5
240R	dB	75	84	84	87	85	76	71	82	dB(A)	89,0
260R	dB	78	84	84	87	85	77	71	82	dB(A)	89,0
300R	dB	80	84	84	87	84	78	74	82	dB(A)	89,0
360R	dB	80	95	90	87	89	81	74	72	dB(A)	91,5
390R	dB	82	95	90	87	88	81	74	73	dB(A)	91,5
450R	dB	82	87	87	90	87	80	77	85	dB(A)	92,0
520R	dB	81	87	87	90	88	80	74	85	dB(A)	92,0
600R	dB	83	87	87	90	87	81	77	85	dB(A)	92,0

(1) In dB ref=10⁻¹² W, as a guideline. Measured in accordance with ISO 9614-1.

(2) In dB ref=10⁻¹² W, (A) weighting, with an uncertainty of +/-3 dB. Measured in accordance with ISO 9614-1 and certified by Eurovent.

■ Sound pressure level (Lp)

Measurement conditions: free field, 10 metres from machine, 1.5 metres above floor level, directivity 2

Note: The sound pressure levels depend on the installation conditions of each system. As such, the levels listed here are given for information only. Only the sound power levels are comparable and certified.

AQUACIAT LD Standard unit	Sound pressure spectrum ⁽¹⁾									Global sound pressure spectrum ⁽²⁾	
		63 Hz	125 Hz	250 Hz	500 Hz	1 kHz	2 kHz	4 kHz	8 kHz		
150R	dB	44	45	48	46	47	41	34	39	dB(A)	50,0
180R	dB	44	47	48	47	48	40	34	38	dB(A)	50,5
200R	dB	43	45	47	47	50	42	34	38	dB(A)	52,0
202R	dB	43	45	47	47	50	42	34	38	dB(A)	52,0
240R	dB	43	52	53	55	54	44	40	50	dB(A)	57,5
260R	dB	46	53	53	56	53	45	40	50	dB(A)	57,5
300R	dB	49	52	53	55	53	46	43	50	dB(A)	57,5
360R	dB	49	63	59	56	57	50	42	41	dB(A)	60,0
390R	dB	50	64	59	56	57	50	42	41	dB(A)	60,0
450R	dB	51	56	56	59	56	49	45	54	dB(A)	60,5
520R	dB	49	56	56	59	56	48	43	53	dB(A)	60,5
600R	dB	52	55	56	58	56	49	46	53	dB(A)	60,5

(1) In dB ref=2x10⁻⁵ Pa, as a guideline.

(2) In dB ref=2x10⁻⁵ Pa, (A) weighting with an uncertainty of +/-3 dB.

SOUND LEVELS

Unit with Xtra Low Noise option

■ Sound power level (LW)

AQUACIAT LD Xtra Low Noise option	Power level spectrum ⁽¹⁾									Global sound power level ⁽²⁾	
		63 Hz	125 Hz	250 Hz	500 Hz	1 kHz	2 kHz	4 kHz	8 kHz		
150R	dB	74	81	78	74	75	68	61	68	dB(A)	78,5
180R	dB	75	81	77	75	76	68	62	68	dB(A)	79,0
200R	dB	72	80	76	74	78	69	61	68	dB(A)	80,0
202R	dB	72	80	76	74	78	69	61	68	dB(A)	80,0
240R	dB	72	80	77	74	78	68	62	67	dB(A)	80,0
260R	dB	75	80	76	76	77	70	62	68	dB(A)	80,0
300R	dB	77	80	78	76	77	71	64	68	dB(A)	80,0
360R	dB	77	82	81	79	80	72	65	71	dB(A)	83,0
390R	dB	79	85	82	79	80	72	65	72	dB(A)	83,0
450R	dB	79	83	81	79	79	74	67	72	dB(A)	83,0
520R	dB	78	83	79	79	80	73	65	71	dB(A)	83,0
600R	dB	80	83	81	79	80	74	67	71	dB(A)	83,0

(1) In dB ref=10⁻¹² W, as a guideline. Measured in accordance with ISO 9614-1.

(2) In dB ref=10⁻¹² W, (A) weighting, with an uncertainty of +/-3 dB. Measured in accordance with ISO 9614-1 and certified by Eurovent.

■ Sound pressure level (Lp)

Measurement conditions: free field, 10 metres from machine, 1.5 metres above floor level, directivity 2

Note: The sound pressure levels depend on the installation conditions of each system. As such, the levels listed here are given for information only. Only the sound power levels are comparable and certified.

AQUACIAT LD Xtra Low Noise option	Sound pressure spectrum ⁽¹⁾									Global sound pressure spectrum ⁽²⁾	
		63 Hz	125 Hz	250 Hz	500 Hz	1 kHz	2 kHz	4 kHz	8 kHz		
150R	dB	43	49	46	43	43	36	30	37	dB(A)	47,0
180R	dB	44	50	46	43	44	37	31	37	dB(A)	47,5
200R	dB	41	49	45	43	46	38	29	36	dB(A)	48,5
202R	dB	41	49	45	43	46	38	29	36	dB(A)	48,5
240R	dB	41	48	45	42	47	37	30	36	dB(A)	48,5
260R	dB	44	48	45	44	46	38	30	36	dB(A)	48,5
300R	dB	45	48	46	44	45	39	33	37	dB(A)	48,5
360R	dB	45	50	49	47	49	41	33	39	dB(A)	51,5
390R	dB	47	54	50	48	48	41	33	40	dB(A)	51,5
450R	dB	48	52	49	48	48	42	35	40	dB(A)	51,5
520R	dB	47	51	48	47	49	41	33	39	dB(A)	51,5
600R	dB	48	51	49	47	48	42	36	40	dB(A)	51,5

(1) In dB ref=2x10⁻⁵ Pa, as a guideline.

(2) In dB ref=2x10⁻⁵ Pa, (A) weighting with an uncertainty of +/-3 dB.

SOUND LEVELS

Standard unit/Unit with High outdoor temperature option

■ Sound power level (L_w)-Cooling mode

AQUACIAT ILD Standard unit / Unit with High outdoor temperature option	Power level spectrum ⁽¹⁾									Global sound power level ⁽²⁾	
		63 Hz	125 Hz	250 Hz	500 Hz	1 kHz	2 kHz	4 kHz	8 kHz		
150R	dB	74,5	77	81	79	78	72	66	71	dB(A)	82,0
180R	dB	76	79	82	80	80	73	66	71	dB(A)	83,0
200R	dB	76	77	81	79	82	75	67	71	dB(A)	84,0
240R	dB	77,5	92	88	85	86	78	71	70	dB(A)	89,0
260R	dB	80	93	89	86	86	79	71	70	dB(A)	89,5
300R	dB	82	93	89	86	86	80	75	75	dB(A)	89,5
360R	dB	80	101	90	87	88	81	74	74	dB(A)	92,0
390R	dB	82,5	92	91	89	89	82	74	75	dB(A)	92,0
450R	dB	84	96	92	88	88	82	77	77	dB(A)	92,0
520R	dB	83	96	92	89	89	82	74	73	dB(A)	92,5
600R	dB	84,5	95	92	88	88	83	77	77	dB(A)	92,0

(1) In dB ref=10⁻¹² W, as a guideline. Measured in accordance with ISO 9614-1.

(2) In dB ref=10⁻¹² W, (A) weighting, with an uncertainty of +/-3 dB. Measured in accordance with ISO 9614-1 and certified by Eurovent.

■ Sound pressure level (L_p) - Cooling mode

Measurement conditions: free field, 10 metres from machine, 1.5 metres above floor level, directivity 2

Note: The sound pressure levels depend on the installation conditions of each system. As such, the levels listed here are given for information only. Only the sound power levels are comparable and certified.

AQUACIAT ILD Standard unit	Sound pressure spectrum ⁽¹⁾									Global sound pressure spectrum ⁽²⁾	
		63 Hz	125 Hz	250 Hz	500 Hz	1 kHz	2 kHz	4 kHz	8 kHz		
150R	dB	43	46	49	47	47	41	35	39	dB(A)	50
180R	dB	44,5	48	50	48	48	41	35	40	dB(A)	52
200R	dB	44,5	45	49	48	51	43	35	40	dB(A)	53
240R	dB	46	61	57	53	55	47	40	39	dB(A)	58
260R	dB	48,5	62	58	54	55	48	40	38	dB(A)	58
300R	dB	50,5	61	58	54	54	49	43	43	dB(A)	58
360R	dB	48,5	69	58	56	57	49	42	42	dB(A)	60
390R	dB	51	61	60	57	58	50	43	43	dB(A)	61
450R	dB	52,5	64	60	57	57	51	45	45	dB(A)	60
520R	dB	51,5	65	61	57	58	51	43	41	dB(A)	61
600R	dB	53	64	60	57	57	51	46	46	dB(A)	60

(1) In dB ref=2x10⁻⁵ Pa, as a guideline.

(2) In dB ref=2x10⁻⁵ Pa, (A) weighting with an uncertainty of +/-3 dB.

SOUND LEVELS

Unit with Xtra Low Noise option

■ Sound power level (L_w)-Cooling mode

AQUACIAT ILD Xtra Low Noise option	Power level spectrum ⁽¹⁾									Global sound power level ⁽²⁾	
		63 Hz	125 Hz	250 Hz	500 Hz	1 kHz	2 kHz	4 kHz	8 kHz		
150R	dB	73,5	74	79	74	75	68	62	70	dB(A)	78,5
180R	dB	75	77	79	75	76	68	62	70	dB(A)	79,0
200R	dB	74	73	78	75	79	69	62	70	dB(A)	80,5
240R	dB	73,5	74	78	74	79	69	62	67	dB(A)	80,5
260R	dB	77	77	79	76	78	71	62	69	dB(A)	80,5
300R	dB	78	77	80	77	78	72	65	69	dB(A)	80,5
360R	dB	77	77	82	79	81	73	66	73	dB(A)	83,5
390R	dB	79	81	84	79	80	73	66	73	dB(A)	83,5
450R	dB	80,5	80	83	80	80	74	67	73	dB(A)	83,5
520R	dB	80	80	82	79	81	74	65	72	dB(A)	83,5
600R	dB	81	80	83	80	81	75	68	72	dB(A)	83,5

(1) In dB ref=10⁻¹² W, as a guideline. Measured in accordance with ISO 9614-1.

(2) In dB ref=10⁻¹² W, (A) weighting, with an uncertainty of +/-3 dB. Measured in accordance with ISO 9614-1 and certified by Eurovent.

■ Sound pressure level (L_p) - Cooling mode

Measurement conditions: free field, 10 metres from machine, 1.5 metres above floor level, directivity 2

Note: The sound pressure levels depend on the installation conditions of each system. As such, the levels listed here are given for information only. Only the sound power levels are comparable and certified.

AQUACIAT ILD Xtra Low Noise option	Sound pressure spectrum ⁽¹⁾									Global sound pressure spectrum ⁽²⁾	
		63 Hz	125 Hz	250 Hz	500 Hz	1 kHz	2 kHz	4 kHz	8 kHz		
150R	dB	42	42	48	43	43	36	30	39	dB(A)	47
180R	dB	43,5	45	48	43	44	37	31	39	dB(A)	48
200R	dB	42,5	42	47	43	47	38	30	39	dB(A)	49
240R	dB	42	43	47	43	47	37	31	36	dB(A)	49
260R	dB	45,5	46	47	45	47	40	31	37	dB(A)	49
300R	dB	46,5	45	48	45	46	40	33	38	dB(A)	49
360R	dB	45,5	45	51	48	50	42	34	42	dB(A)	52
390R	dB	47,5	50	52	48	49	42	34	42	dB(A)	52
450R	dB	49	48	51	48	49	43	36	41	dB(A)	52
520R	dB	48,5	49	50	48	50	43	34	40	dB(A)	52
600R	dB	49,5	48	51	48	49	43	36	41	dB(A)	52

(1) In dB ref=2x10⁻⁵ Pa, as a guideline.

(2) In dB ref=2x10⁻⁵ Pa, (A) weighting with an uncertainty of +/-3 dB.

SYSTEM WATER VOLUME - EVAPORATOR WATER FLOW RATE

The Connect Touch control is equipped with anticipation logic making it highly flexible in adjusting operation to parameter drift, particularly on hydraulic systems with low water volumes. By adjusting compressor running times, it prevents short cycle protection cycles from starting and, in most cases, eliminates the need for a buffer tank.

NOTE: The minimum volumes of chilled water are calculated for EUROVENT rated conditions:

Cooling mode, LD version

- Chilled water temperature = 12°C/7°C
- Condenser air inlet temperature = 35°C

Heating mode, ILD version

- Hot water temperature = 40°C/45°C
- Outdoor air temperature = 7°C

This value is applicable for most air conditioning applications (unit with fan coil units)

Note: For installations running with a low volume of water (unit with air handling unit) or for industrial processes, the buffer tank is essential.

■ Minimum system water volume and water type heat exchanger flow rate

AQUACIAT LD	150R	180R	200R	202R	240R	260R	300R	360R	0390R	450R	520R	600R
Minimum system water volume, air conditioning application (litres)	125	135	165	165	185	210	245	270	210	245	420	485
Minimum system water volume, industrial process application (litres)	295	325	390	395	435	500	575	640	500	575	1000	1155
Min/max water type heat exchanger flow rate without hydronic module ⁽¹⁾ (l/s)	0,9 / 3	0,9 / 3,4	0,9 / 4,2	0,9 / 4,2	0,9 / 5	1 / 5	1,2 / 5,5	1,3 / 6,8	1,5 / 7,7	1,7 / 8,5	2 / 10,6	2,3 / 11,2
Maximum water exchanger flow rate Dual high pressure pump (l/s) ^{(2) (3)}	3,4	3,8	4,4	4,4	5	5	5,2	6,2	6,5	8	8,7	8,9

AQUACIAT ILD	150R	180R	200R	240R	260R	300R	360R	0390R	450R	520R	600R
Minimum system water volume, air conditioning application (litres) - Cooling	200	220	265	300	340	400	440	340	400	685	795
Minimum system water volume, air conditioning application (litres) - Heating	365	395	475	530	610	710	785	610	710	1220	1420
Minimum system water volume, industrial process application (litres)	270	295	355	395	455	530	585	455	530	910	1060
Min/max water type heat exchanger flow rate without hydronic module ⁽¹⁾ (l/s)	0,9 / 3	0,9 / 3,4	0,9 / 4,2	0,9 / 5	1 / 5	1,2 / 5,5	1,3 / 6,8	1,5 / 7,7	1,7 / 8,5	2 / 10,6	2,3 / 11,2
Maximum water exchanger flow rate Dual high pressure pump (l/s) ^{(2) (3)}	3,4	3,8	4,4	5	5	5,2	6,2	6,5	8	8,7	8,9

(1) Maximum flow rate for a pressure drop of 100 kPa in the water exchanger

(2) Maximum flow rate at an available pressure of 50 kPa (high pressure).

(3) Maximum flow rate with single pump 2 to 4% higher, depending on the size.

NOTE: For the Buffer Tank Module option, the volume of the tank must be taken into account

OPERATING RANGE

AQUACIAT devices have a broad field of application, enabling them to meet a range of heating and cooling requirements in the most varied of climates.

Multi-application: air conditioning, heating, industrial processes

The **AQUACIAT** can be used for all traditional air conditioning and heating applications in sectors as varied as shared residential, hotels, shopping centres and offices.

■ Operating limits of the LD water chiller ❄️

Multi-climate: -20°C to +46°C

The **AQUACIAT** is equipped as standard with all the components and algorithms required to enable year-round operation down to -10°C with the option to extend operation to -20°C thanks to the variable-speed fan option.

Standard unit & Xtra Low Noise version

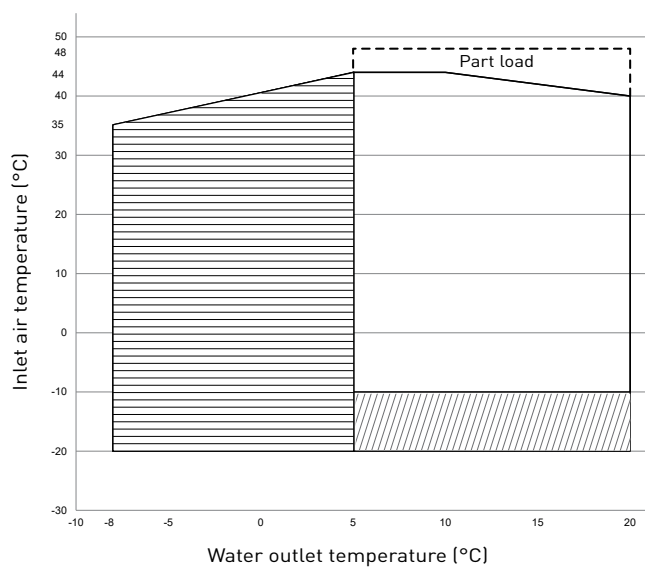

Unit with high outdoor temperature option

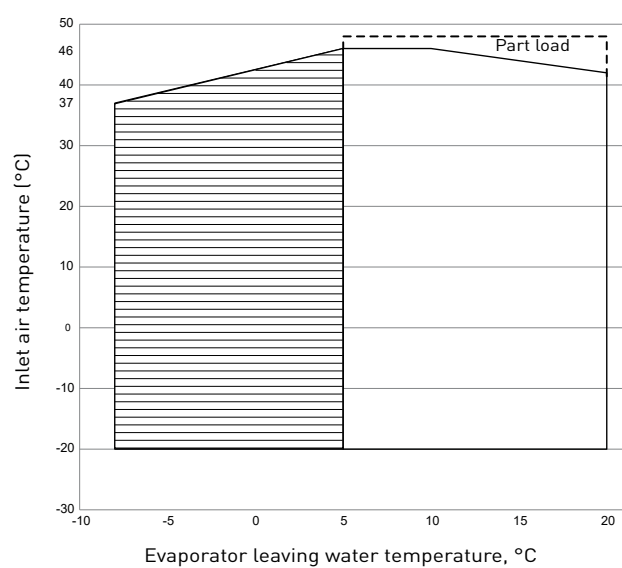

Notes:

1. Water type heat exchanger $\Delta T = 5K$.
2. The hydronic module and/or water type heat exchanger must be protected against frost (low water temperature option)
The loop must be protected by an antifreeze solution for outdoor temperatures $< 0^\circ C$.
3. Operating ranges are guidelines only. Verify the operating range with the electronic catalogue.

Key:

- Operating range at full load
- Extension of the operating range for **AQUACIAT LD** Low temperature brine solution, XtraFan, Xtra Low noise, EC fans, winter starting option: frost protection required (see note 2).
- Operating range for partial load units
- Extension of the operating range for **AQUACIAT LD** Low temperature brine solution option (see note 2).

OPERATING RANGE

■ Operating limits of the ILD heat pump

Multi-climate

The design of the **AQUACIAT** makes it suitable for the majority of heating and air conditioning applications, regardless of the climate. Water heated to +40°C is guaranteed, even for outdoor temperatures of -10°C

**Operating map in cooling mode -
AQUACIAT ILD Standard unit /
Option Xtra Low Noise** ❄️

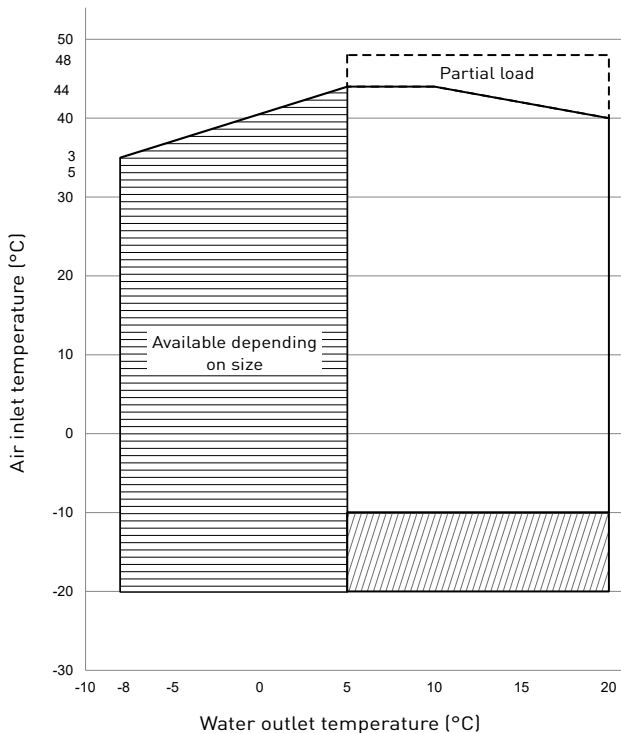

**Operating map in heating mode -
AQUACIAT ILD
Standard unit** ☀️

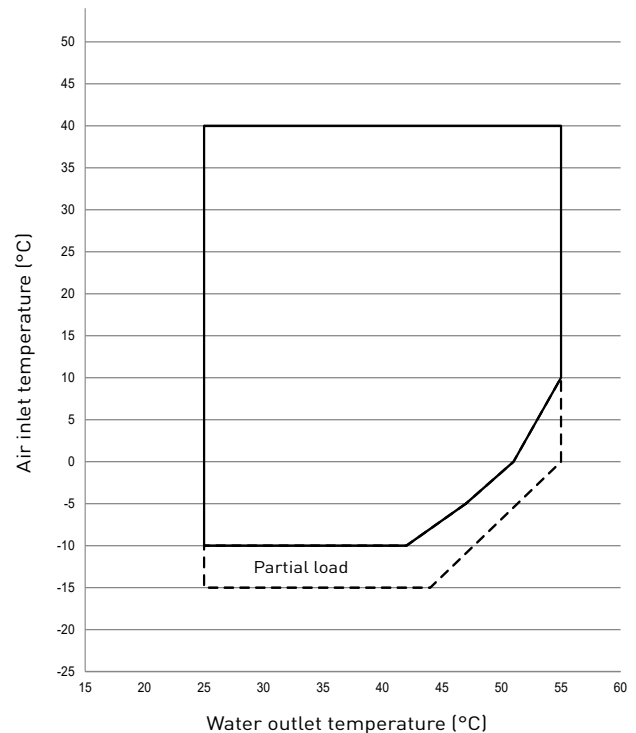

Notes:

1. Water type heat exchanger $\Delta T = 5K$.
2. The hydronic module and/or water type heat exchanger must be protected against frost (low water temperature option)
The loop must be protected by an antifreeze solution for outdoor temperatures $< 0^\circ C$.
AQUACIAT ILD 150R/180R, ==> LWT min $0^\circ C$
3. Operating ranges are guidelines only. Verify the operating range with the electronic catalogue.

Key:

- Operating range at full load
- Extended operating range **AQUACIAT ILD** option Low temperature brine solution, XtraFan, Xtra Low noise, EC Fans, Cooling operation down to $-20^\circ C$: anti-freeze protection necessary (see note 2).
- Operating range for partial load units.
- Extended operating range **AQUACIAT ILD** option Low temperature brine solution (See note 2).

OPERATING RANGE

**Operating map in heating mode -
AQUACIAT ILD - with heating optimized option**

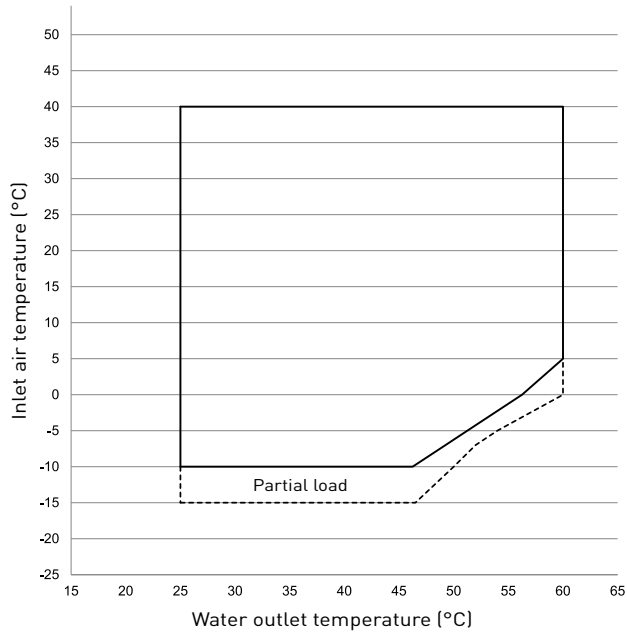

**Operating map in cooling mode -
AQUACIAT ILD - with heating optimized option**

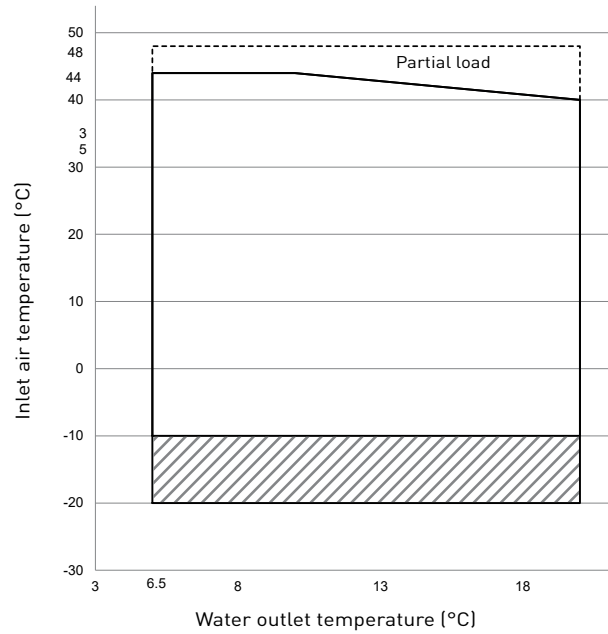

Notes:

1. Water heat exchanger $\Delta T = 5K$.
2. The unit must either be equipped with the frost protection option for the water heat exchanger and the hydronic module (if used), or the water loop must be protected against frost by the installer using an anti-freeze solution for outdoor air temperatures below 0°C.
3. Operating ranges are guidelines only. The operating range must be checked with the selection software.

Key:

- Operating range at full load.
- Extended operating range AQUACIAT LD option XtraFan, Xtra Low noise, EC Fans, Cooling operation down to -20°C : anti-freeze protection necessary [see note 2]
- Partial load operating range

HYDRAULIC SPECIFICATIONS

■ Water pressure drop in the evaporator

Data applicable for pure water at 20°C

LD/ILD sizes 150R-600R

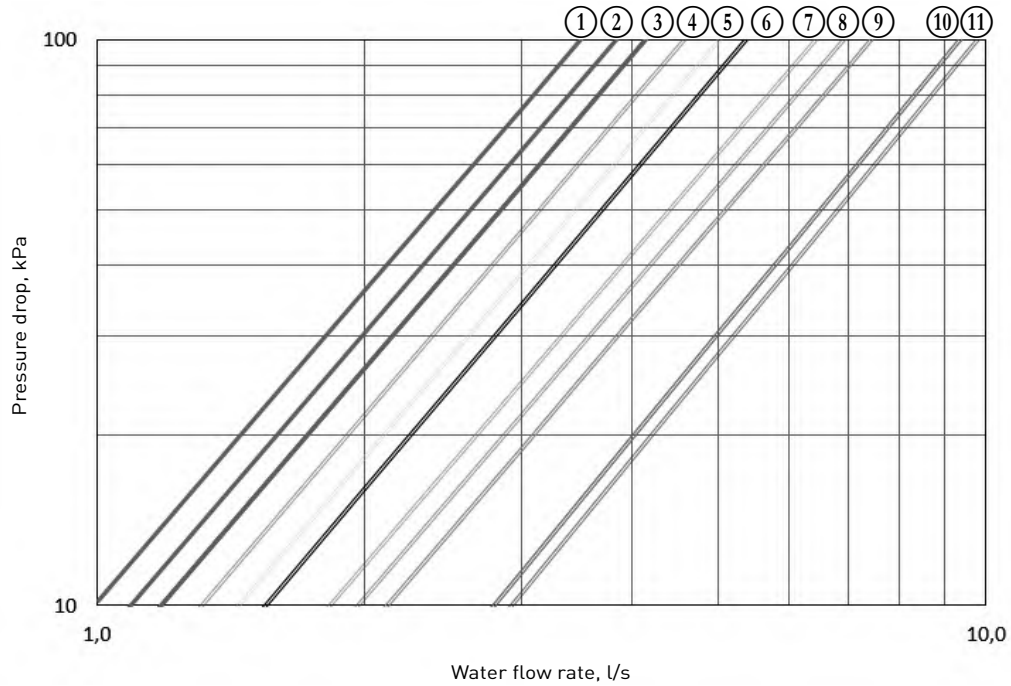

- ① LD/ILD-150R
- ② LD/ILD-180R
- ③ LD/ILD-200R - 202R
- ④ LD/ILD-240R
- ⑤ LD/ILD-260R
- ⑥ LD/ILD-300R

- ⑦ LD/ILD-360R
- ⑧ LD/ILD-390R
- ⑨ LD/ILD-450R
- ⑩ LD/ILD-520R
- ⑪ LD/ILD-600R

HYDRAULIC SPECIFICATIONS

■ Water pressure drop in the filter

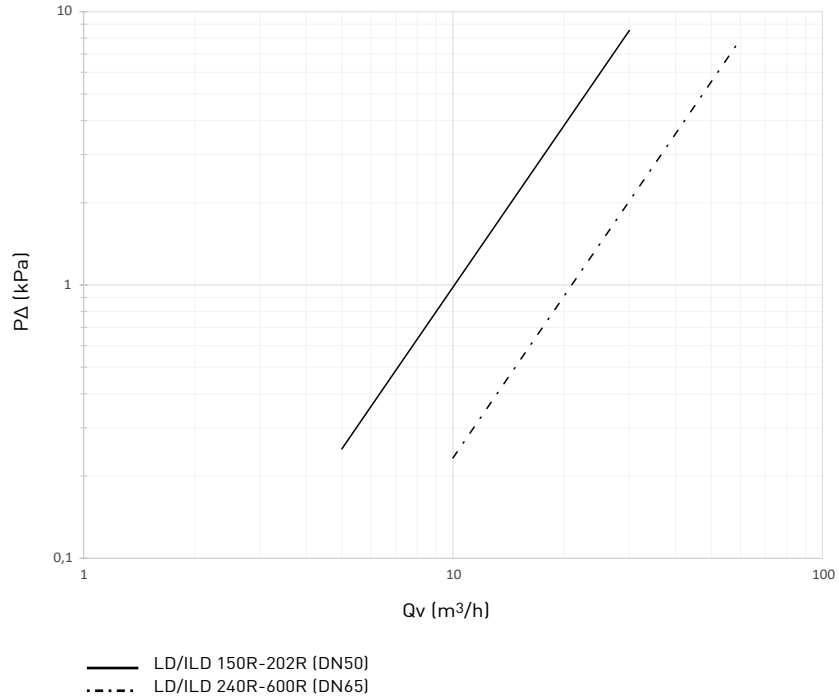

■ Water pressure drop in the buffer tank

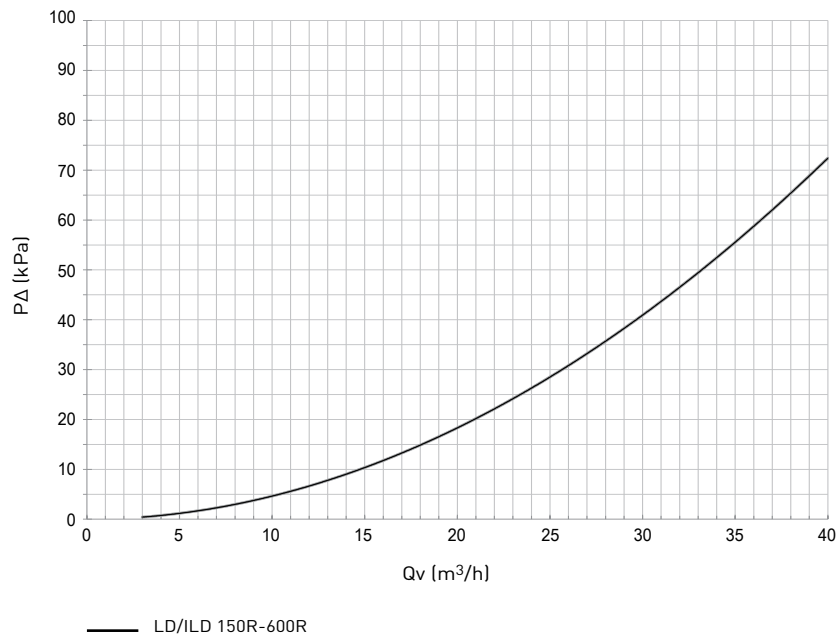

HYDRAULIC SPECIFICATIONS

■ Available static system pressure

Units with hydronic module (fixed-speed pump or variable-speed pump at 50 Hz)

Data applicable for:

- Pure water at 20°C
- Refer to the section "Evaporator water flow rate" for the minimum and maximum water flow rate values
- If brine is used, the maximum water flow rate is reduced.

Low pressure pumps

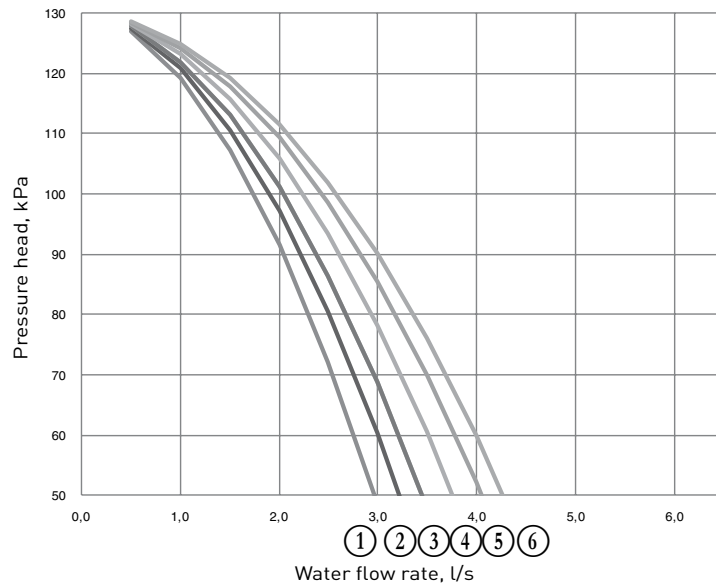

- | | |
|------------------------|-----------------|
| ① LD/ILD - 150R | ④ LD/ILD - 240R |
| ② LD/ILD - 180R | ⑤ LD/ILD - 260R |
| ③ LD/ILD - 200R - 202R | ⑥ LD/ILD - 300R |

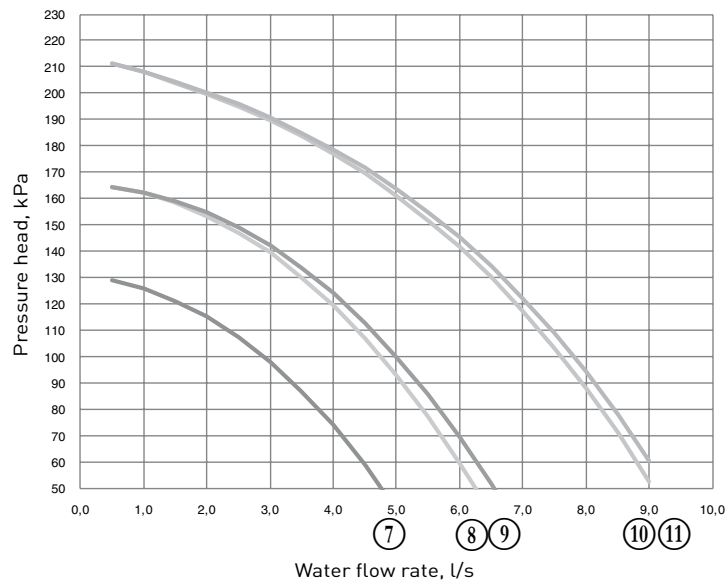

- | | |
|-----------------|-----------------|
| ① LD/ILD - 360R | ④ LD/ILD - 520R |
| ② LD/ILD - 390R | ⑤ LD/ILD - 600R |
| ③ LD/ILD - 450R | |

HYDRAULIC SPECIFICATIONS

High pressure pumps

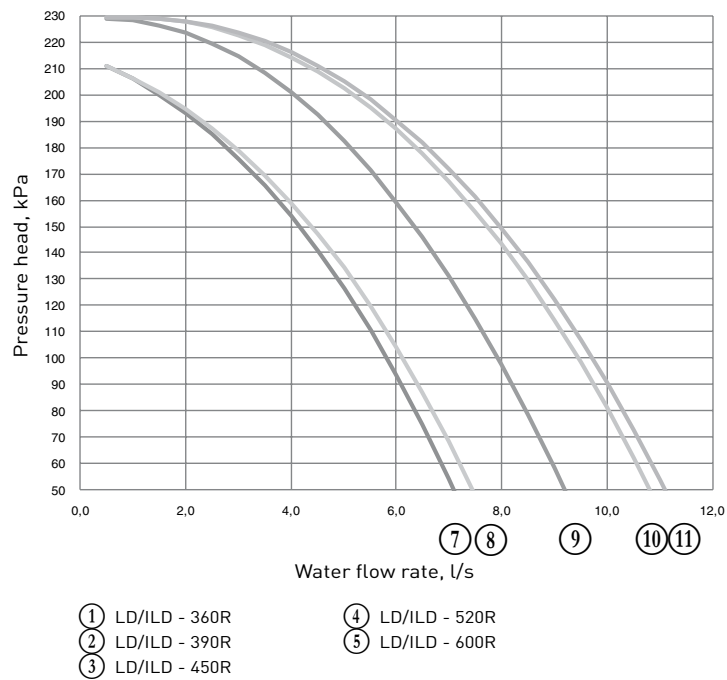
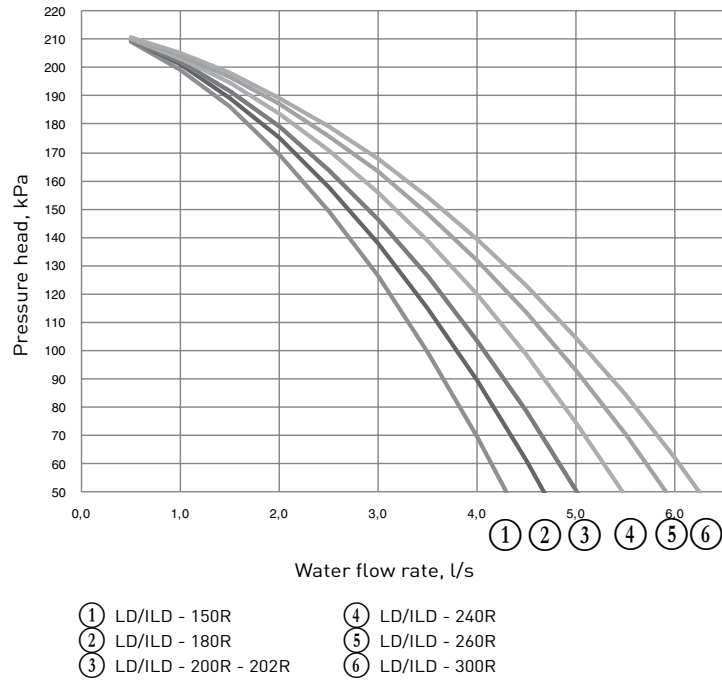

DIMENSIONS

■ AQUACIAT LD-ILD 150R to 300R without buffer tank

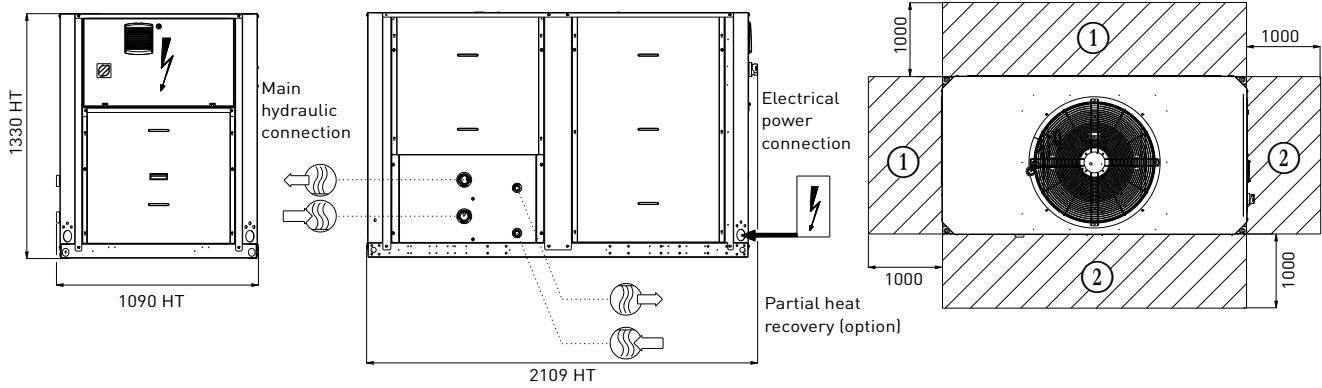

■ AQUACIAT LD-ILD 150R to 300R with buffer tank

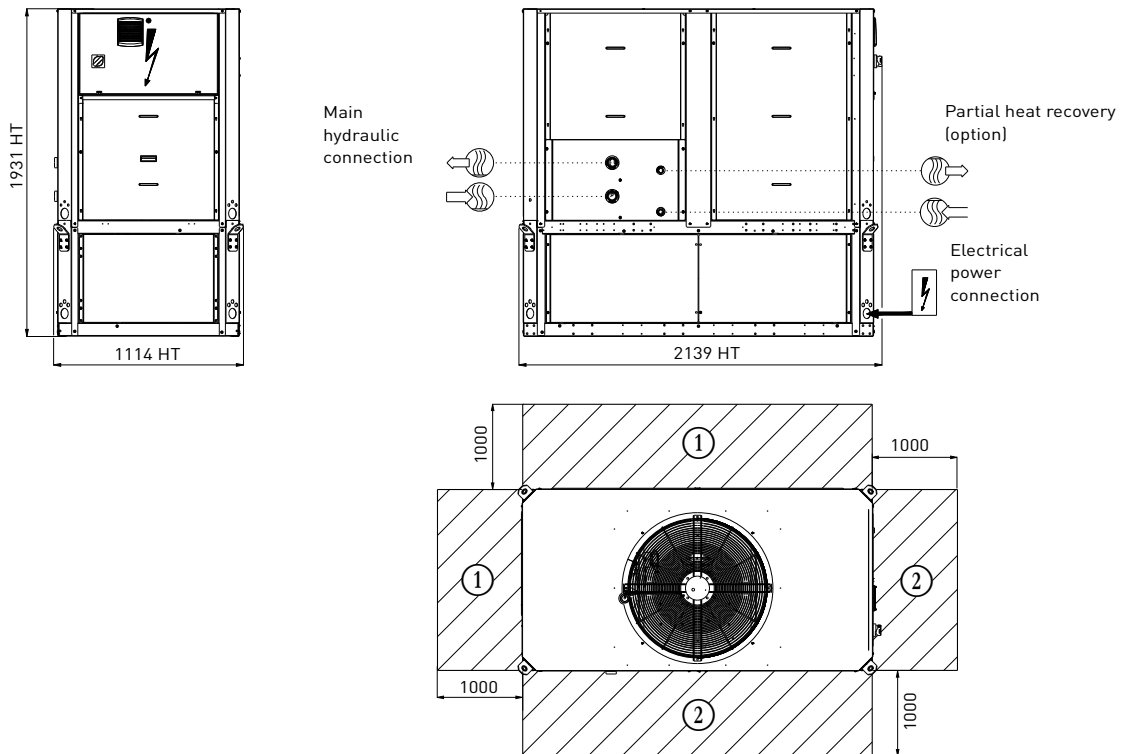

Key

All dimensions in mm

① Clearance required for maintenance and air flow

② Clearance recommended for coil removal

Water inlet

Water outlet

Air outlet, do not obstruct

Electrical cabinet

NOTES:

Non-contractual drawings.

When designing a system, refer to the certified dimensional drawings provided with the unit or available on request.

Refer to the certified dimensional drawings for:

- The location of the fixing points,
- The weight distribution,
- The centre of gravity coordinates,
- Details of the XtraFan and return air frame option connections.

DIMENSIONS

■ AQUACIAT LD-ILD 360R to 600R without buffer tank

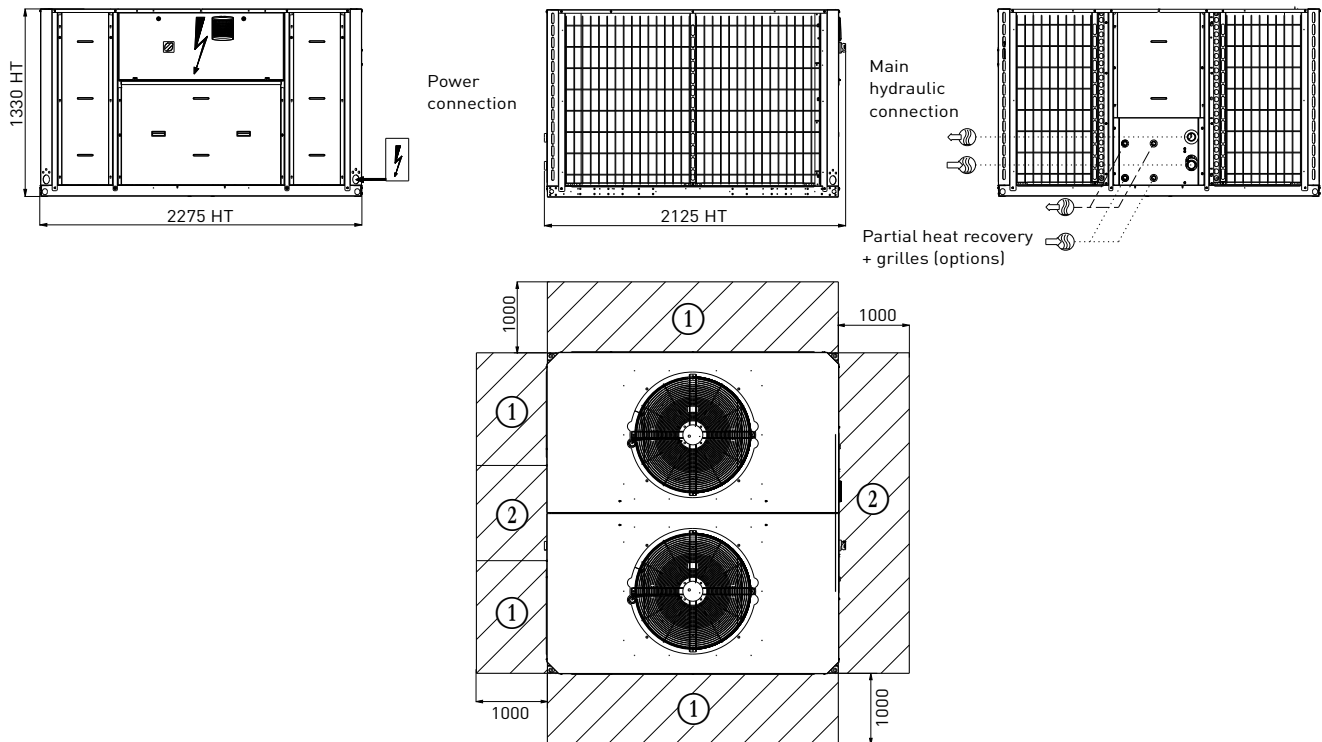

Key

All dimensions in mm

① Clearance required for maintenance and air flow

② Clearance recommended for coil removal

Water inlet

Water outlet

Air outlet, do not obstruct

Electrical cabinet

NOTES:

Non-contractual drawings.

When designing a system, refer to the certified dimensional drawings provided with the unit or available on request.

Refer to the certified dimensional drawings for:

- The location of the fixing points,
- The weight distribution,
- The centre of gravity coordinates,
- Details of the XtraFan and return air frame option connections.

DIMENSIONS

■ AQUACIAT LD-ILD 360R to 600R with buffer tank

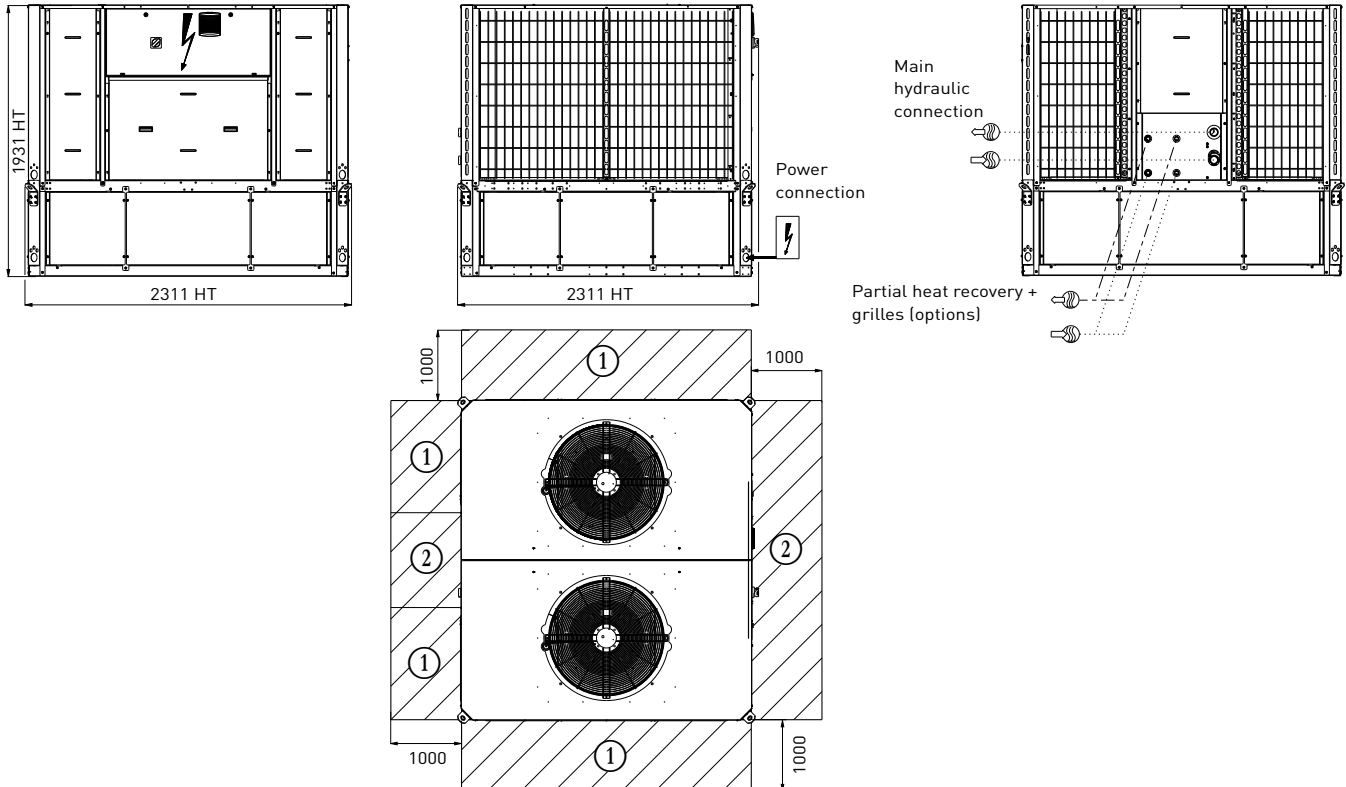

Key

All dimensions in mm

① Clearance required for maintenance and air flow

② Clearance recommended for coil removal

Water inlet

Water outlet

Air outlet, do not obstruct

Electrical cabinet

NOTES:

Non-contractual drawings.

When designing a system, refer to the certified dimensional drawings provided with the unit or available on request.

Refer to the certified dimensional drawings for:

- The location of the fixing points,
- The weight distribution,
- The centre of gravity coordinates,
- Details of the XtraFan and return air frame option connections.

INSTALLATION RECOMMENDATIONS

■ Water quality criteria to be respected

WARNING: *It is essential that an 800-micron water filter be placed on the unit's water inlet during installation. The quality of the water used has a direct impact on the correct and compliant operation of the machine and its service life. This is particularly true if the water used clogs or corrodes components or promotes the growth of algae or micro-organisms. The water must be tested to determine whether it is suitable for the unit. It is also tested to determine whether chemical treatment is necessary and will suffice to make it of acceptable quality. This analysis should confirm whether or not the various machine components are compatible with the water they come into contact with on-site.*

WARNING: *Failure to follow these instructions will result in the immediate voiding of the unit's warranty.*

■ Lifting and handling

The utmost safety precautions must be taken when lifting and handling the unit.

Always follow the lifting diagram on the unit and in the instruction manual.

Before attempting to lift the unit, make sure the path leading to its intended location is free from obstacles. Always keep the unit vertical when moving it. Never tip it or lie it on its side.

■ Choosing a location for the unit

AQUACIAT units are designed for outdoor installation. Precautions should be taken to protect them from freezing temperatures. Special attention should be paid to ensure sufficient free space (including at the top) to allow maintenance. The unit must be placed on a perfectly level, fireproof surface strong enough to support it when ready for operation. Noise pollution from auxiliary equipment such as pumps should be studied thoroughly.

Potential noise transmission routes should be studied, with assistance from an acoustical engineer if necessary, before installing the unit. It is strongly recommended that flexible couplings are placed over pipes and anti-vibration mounts are fitted underneath the unit (equipment available as an option) to reduce vibrations, and the noise this causes, as much as possible.

■ Fitting accessories supplied separately

A number of optional accessories may be delivered separately and installed on the unit on site.

You must follow the instructions in the manual.

■ Electrical connections

You must follow the instructions in the manual. All information concerning electrical connections is stated on the wiring diagrams provided with the unit. Always follow this information to the letter.

Electrical connections must be made in accordance with best current practices and applicable standards and regulations. Electrical cable connections to be made on-site:

- Electrical power supply to unit
- Contacts available as standard enabling the machine to be controlled remotely (optional)

It should be noted that the unit's electrical system is not protected against lightning strikes.

Therefore devices to protect against transient voltage surges must be installed on the system and inside the power supply unit.

INSTALLATION RECOMMENDATIONS

■ Pipe connections

You must follow the instructions in the manual. All pipes must be correctly aligned and slope towards the system's drain valve. Pipes must be installed to allow sufficient access to the panels for maintenance, and must be fitted with heat insulation.

Pipe fixings and brackets must be separate to avoid vibrations and ensure no pressure is placed on the unit. Water flow shut-off and control valves must be fitted when the unit is installed.

Pipe connections to be made on site:

- Water supply with pressure-reducing valve
- Evaporator, condenser and drain
- Accessories essential to any hydraulic circuit must also be installed, such as:
 - Water expansion tank
 - Drain nozzles at pipe low points
 - Exchanger shut-off valves equipped with filters
 - Air vents at pipe high points
- Check the system's water capacity (install a buffer tank if necessary)
- Flexible couplings on exchanger inlets and outlets

WARNING:

- ***Pressure in the hydraulic circuits below 4 bar for units equipped with the hydronic module***
- ***Place the expansion tank before the pump.***
- ***Do not place any valves on the expansion tank.***
- ***Make sure the water circulation pumps are placed directly at the exchanger inlets.***
- ***Make sure the pressure of the water drawn in by the circulation pumps is greater than or equal to the required minimum NPSH, particularly if the hydraulic circuits are open".***
- ***Test the water quality in accordance with the relevant technical requirements.***
- ***Take the necessary precautions to protect the unit and hydraulic system from freezing temperatures (e.g. allow for the possibility of draining the unit). If glycol is added to prevent freezing, check its type and concentration before system start-up.***
- ***Before making any final hydraulic connections, flush the pipes with clean water to remove any debris in the network***

■ System start-up

System start-up for these machines must be performed by CIAT or a CIAT-authorized firm.

You must follow the instructions in the manual.

List of system start-up checks (non-exhaustive):

- Correct positioning of the unit
- Power supply protections
- Phases and direction of rotation
- Wiring connections on the unit
- Direction of water flow in the unit
- Cleanliness of the hydraulic circuit
- Water flow rate at the specified value
- Pressure in the refrigerant circuit
- Direction of rotation of the compressors
- Water pressure drops and flow rates
- Operating readings

■ Maintenance operations

Specific preventive maintenance operations are required at regular intervals and should be performed by CIAT-approved contractors.

The operating parameters are read and noted on a "CHECK LIST" form to be returned to CIAT.

To do this, you must refer to and comply with the instruction manual.

You must take out a maintenance contract with a CIAT-approved refrigeration equipment specialist. Such a contract is required even during the warranty period.

CONTROL

USER-FRIENDLY INTERFACE CONSOLE

- User-friendly 4.3-inch touch screen.
- Information displayed in a choice of languages.
- Temperature and pressure readings.
- Operating and fault status diagnostics.
- Lead/Lag control of two machines in parallel.
- Fault memory management.
- Pump management.
- Time schedule.
- IP Web server.
- Programmable maintenance.
- Preventive maintenance.
- FGAS maintenance.
- E-mail alerts.



REMOTE ABOUND HVAC Performance MACHINE SUPERVISION

Full Serenity with:

- Monitoring of machine operation (operation overviews and curves, alarm logs).
- E-mail alerts for alarms (optional SMS alerts).
- Remote update of the **ABOUND HVAC Performance**.
- Access to a log of machine operation data.
- Remote advice for using **ABOUND HVAC Performance**.
- System start-up and operating readings.



PRODUCT FUNCTIONALITY



Via potential-free (dry) contact

Customer CMS COMMUNICATION

Via BUS communication

POTENTIAL-FREE (DRY) CONTACTS AVAILABLE AS STANDARD

Inputs:

- Automatic operation control
- Heating/cooling mode selection
- Selection of setpoints 1 / 2
- Power limitation

Outputs:

- General fault reporting
- Circuit fault reporting
- User fault display
- 0-10 V output available for control of a variable flow pump (unit without hydronic module)

Additional inputs available as options:

- Setpoint adjustable by 4-20 mA signal

Additional outputs available as options:

- On/off control for a boiler
- 4-stage on/off management for additional heaters

AVAILABLE OUTPUTS

- MODBUS-JBUS RTU (RS485) or TC/IP (standard) open protocol
- LONWORKS protocol (option)
- BACNET IP protocol (option)

Electrical network

SGR Ready

Heat pump **AQUACIAT ILD** are SGR ready certified, standardized and secured label for integration on the smart electrical networks.

The objective is to improve the management of the load of the electricity network as a function of the fluctuation of the power availability of the latter related to renewable energies (photovoltaic or wind turbine)



CIAT SYSTEM FUNCTIONALITY

Communication with the Hsys system (generator, transmitter, air handling unit), controlled by a EasyCIAT control Smart CIATcontrol touch tablet.

- **Logging** of consumption data and temperatures
- **Optimal Water®**: optimisation of producer performance based on building requirements
- **Optimal Stop and Start** :
Optimisation of the restart time for the building



The quality management system of this product's assembly site has been certified in accordance with the requirements of the ISO 9001 standard (latest current version) after an assessment conducted by an authorized independent third party.

The environmental management system of this product's assembly site has been certified in accordance with the requirements of the ISO 14001 standard (latest current version) after an assessment conducted by an authorized independent third party.

The occupational health and safety management system of this product's assembly site has been certified in accordance with the requirements of the ISO 45001 standard (latest current version) after an assessment conducted by an authorized independent third party.

Please contact your sales representative for more information

Order No.: NA24770A , 07.2024 - Supersedes order No.: NA23770A , 02.2023.

Carrier, Montluel, France.

Manufacturer reserves the right to change any product specifications without notice.

The illustrations in this document are for illustrative purposes only and not part of any offer for sale or contract. The manufacturer reserves the right to change the design at any time without notice.