



## COADIS LINE 900

Comfort units  
COANDA effect cassette



*New generation of cassette comfort units based on the water loop  
360° Coanda effect diffusion  
Energy efficient motor  
and high-efficiency filtration*

Cooling capacity: 3 to 11 kW  
Heating capacity: 3 to 20 kW



## USE

The active water loop comfort unit, for installation in suspended ceilings, can be used to autonomously and individually adapt the indoor temperature over very short

periods to ensure the comfort of occupants. Designed for offices, open plan areas, meeting rooms, commercial premises and entrance halls.

## RANGE

The **COADIS LINE 900** range of cassettes features 9 sizes covering flow rates from 550 to 1400 m<sup>3</sup>/h, and meeting the most stringent sound level requirements.

- 1 Visual 360° diffusion model:
  - Coanda effect diffuser across 360°

- The **COADIS LINE** is available as:
  - A 2-tube system, operating in cooling or heating mode,
  - A 2-tube + 2-wire system, operating in cooling or heating/cooling + electric mode,
  - A 4-tube system, operating in cooling and heating mode.

## ADVANTAGES

- Uses an ecological and long-lasting heat-transfer fluid.
- Individual adaptation of the indoor temperature.
- Responsiveness of the system.
- Extensive capacity range.
- Diffusion by Coanda effect across 360° for comprehensive coverage, and perfect control of thermal phenomena which cause discomfort.
- Acoustic comfort.
- Optimum indoor air quality thanks to the EPURE function.
- Energy optimisation:
  - High Energy Efficiency motor,
  - EPURE filter with low pressure drop,
  - Optimised hydraulic coil.
- Maintenance facilitated by access to the filter and the highly accessible internal components.
- Modern, elegant design to ensure perfect integration.
- Environmentally-responsible product.

## TECHNICAL DESCRIPTION

### Return/supply air interface

- VISUAL 360°  
Painted galvanised steel.  
PSE insulation, 10 to 40 mm thick.  
Uniform RAL 9010 white colour for all components.  
Integration within a suspended ceiling, fitting in the centre of four tiles.  
Perforated metal return air grille with filter housing with quick opening via 2 lugs.  
Interface secured by 4 screws, to be removed to gain full access to the internal components (coil, FMA, temperature limiters, condensate pan, condensate drain pump).  
Coanda effect diffusion which allows a jet of air to follow the ceiling, preventing cold air from dropping into the comfort area. Coanda effect offers 360° coverage of the surface area of the room to be treated, with no dead zone.  
Narrow single-slot opening and specific internal profile.

### Frame

- Ribbed galvanised steel motor support base panel.
- High-density PSE packaged casing, ensuring the acoustic and thermal insulation. 18 mm thick for the base and 25 mm to 30 mm thick for the vertical walls which form the casing. M1 fire rating.
- Low emission of TVOCs and no halogenated compounds.
- ABS technical plate supporting the electrics box, hydraulic and air couplings (fresh air).
- Reinforcing ABS angle bars fitted in the corners and equipped with open galvanised steel mounting brackets with check valve for fitting threaded rods.
- Fixed frame in RAL 9010 (white) painted galvanised steel, housing the return/supply air interface and providing rigidity to the casing assembly.

### Water coil

- 1 hot water or cold water circuit (2-tube system),
- 1 hot water + 1 cold water circuit (4-tube system),
- One-piece coupling (40 mm centre distance) with rotating female couplings with integrated flat face and seals, for easy fitting of control valves,
- One, two or three-row circular coil with low pressure drop,
- Copper tubes, continuous aluminium fins (1.8 mm spacing),
- Bleeding and draining,
- Nominal pressure of 16 bar (at 20°C),
- Test pressure of 24 bar,
- Max. hot water inlet temperature:
  - 4-tube application: 80°C,
  - 2-tube application: 70°C,
  - 2-tube/2-wire application: 55°C (min. air flow rate: 200 m<sup>3</sup>/h)
- Min. cold water inlet temperature: 6°C.

### Electrical heater (2-tube + electric system)

- 230/1/50 single-tube electrical elements inserted into the aluminium housing.
- Two temperature limiters with manual and automatic reset, inserted into the aluminium housing and easily accessible without the need to open the suspended ceiling via the return/supply air interface.
- Heater power supply connected to the terminal block inside the electrics box.
- Option of deactivating a heater on site by removing a shunt from the terminal block, to reduce the electrical power.

### Condensate drain pan

- One-piece main pan with all-climate insulation in high-density PSE, with sealing treatment on the upper section. Removable from below.
- Condensate drainage (internal Ø 32 connection) provided by an internal drain pump equipped with a safety float, check valve and fitted on anti-vibration mounts.
- Auxiliary pan available as an accessory for recovery of condensate from the valves.

### Fan motor assembly

#### ■ HEE motor

- High energy efficiency motor enabling a reduction of up to 85% in electricity consumption.
- BLAC (Brushless Alternating Current) technology offering more linear torque progression and a lower operating sound level than BLDC (Brushless Direct Current) technology,
- Sealed, tropicalised, with protected shaft,
- 3-speed gradual operation by 0-10V or on/off control signal, without expansion board,
- Ball bearings,
- Internal automatic overload protection as standard on winding,
- "DFS" motor fault output using a photocoupler for potential alarm feedback via a Konnex protocol communication bus (via the V3000 controller),
- Fitted on anti-vibration mounts,
- 230V/1Ph/50 Hz power supply (60Hz compatible).

**Note: The minimum voltage required for start-up of the motor is 2V.**

Or

#### ■ Asynchronous motor

- 5 factory-fitted cabled speeds (connected and available at the terminal) for customised adjustment.
- Sealed, tropicalised, with protected shaft,
- Permanent capacitor,
- Ball bearings,
- Internal automatic overload protection as standard on winding,
- Resilient mounts,
- 230V/1Ph/50 Hz power supply (60Hz compatible),
- High efficiency and power factor.

## TECHNICAL DESCRIPTION

### ■ Fan(s)

- Balanced centrifugal impeller (Ø 476mm) with airfoil blades,
- Polymer impeller,
- Single-point mounting system with foolproofing device.

### Electrics box

- Large ABS electrics box, with a hinge to keep it open and screw closure.
- Index of Protection: IP20.
- Terminal block on DIN rail in accordance with EN 50022, depth 7.5 mm.
- Junction block located with tension clamp. Cross section 0.5 to 2.5 mm<sup>2</sup> - Max current: 24A - Shock resistance: 8 kV.
- Cable routing for customer electrical connections.

### Fresh air supply sleeve

- Ø 100 mm sleeve integrated into the casing with removable plug.

### Air filter

#### ■ EPURE function

- A protected air stream which prevents particles present in the suspended ceilings from being drawn in,
- Uniform treatment of the room thanks to optimised diffusion (Coanda effect) and an adapted mixing rate,
- Local filtration by high efficiency filter medium effective on fine particles up to 2.5 microns,
- Filter area 10 times greater than the intake grille surface,
- No discharge from the filter during replacement thanks to the folded filter medium with heat-sealed lateral inserts to make it more rigid
- Longer service life compared to a conventional flat filter, thanks to its high retention capacity,
- Low energy impact,
- Fire rating: M1,
- No release of glass fibres,
- 100% incinerable at end of life.

Or

- Flexible filter medium made of regenerative polyester fibre,
- Efficiency class (EN 779): G3,
- Fire rating: M1,
- Rigid metal frame,
- Accessible via the hinged air recovery grille.

### Unit mounting

Open mounting brackets, factory-fitted, made from galvanised steel, 15/10th thick, with check valve for securing the threaded rods during fitting and levelling.

### Packaging

- Strapped cardboard crate for the casing.
- Fitting template and direction of assembly printed on the box.
- Visual return/supply air interface supplied separately in protective cardboard packaging.
- Delivered on a plastic-wrapped pallet.

### Controls

- V6 electronic thermostat
- V600 electronic thermostat
- V300 electronic range.
- V3000 networked electronic range (KNX).

### Options (factory-fitted)

- Hydraulic coil with blades protected for use in harmful/corrosive atmospheres (coastal locations, or areas close to chemical industries).

### Accessories (available separately)

- 300 mm long flexible connections kit with or without 9 mm insulation.
- Self-adjusting fresh air module kit:
  - 15/30/45 m<sup>3</sup>/h flow rates,
  - 60/75/90 m<sup>3</sup>/h flow rates,
- Ø100/125 mm adapter for fresh air sleeve,
- Resilient mounts,
- Finish frame for STAFF ceiling,
- Fresh air pack:
  - R1: fresh air managed via presence sensor,
  - R+: fresh air management via CO<sub>2</sub> sensor (recommended max. air flow 90 m<sup>3</sup>/h; network balancing system not supplied by CIAT).

## INTEGRATION INTO THE SUSPENDED CEILING

The air handling casing is fitted inside the suspended ceiling, in the centre of 4 tiles, to be positioned in the centre of the room. The **COADIS LINE** must be suspended from the ceiling using 4 threaded rods either 6 mm or 8 mm in diameter (not supplied), which are fixed to the unit's 4 support brackets using resilient mounts or a nut/washer assembly positioned on either side of the mounting bracket.

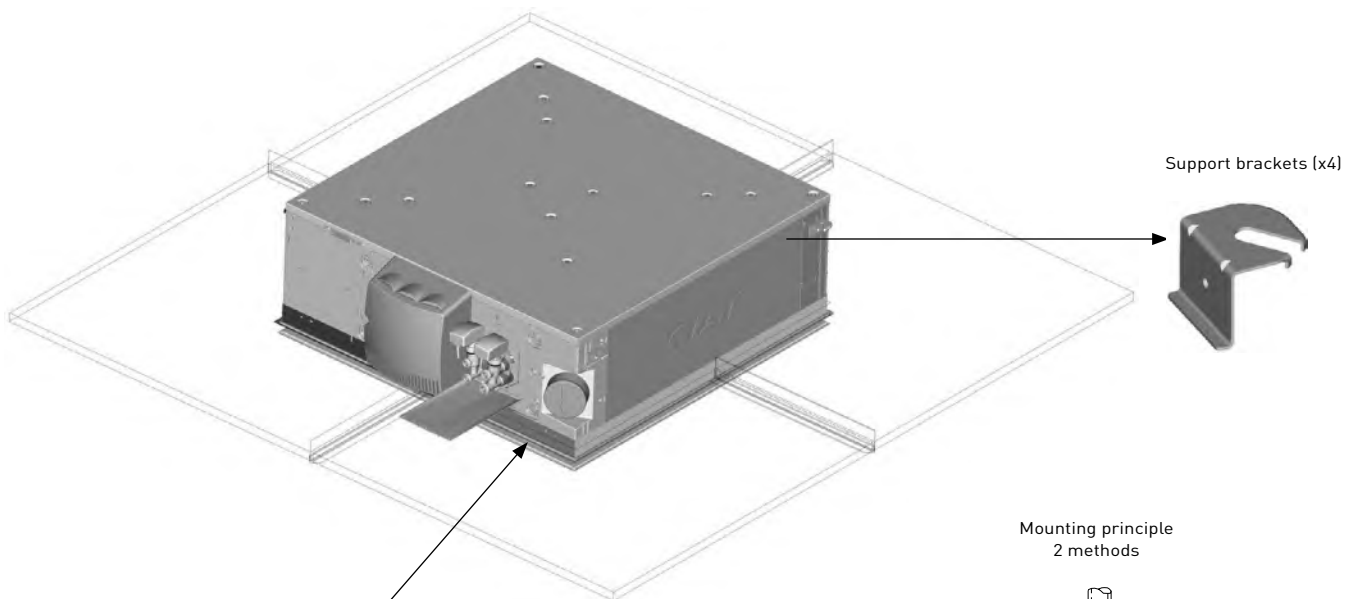
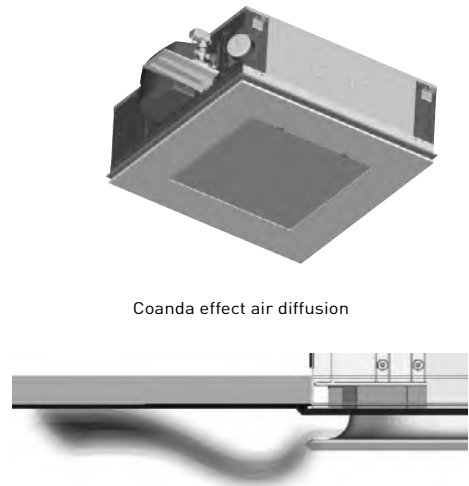
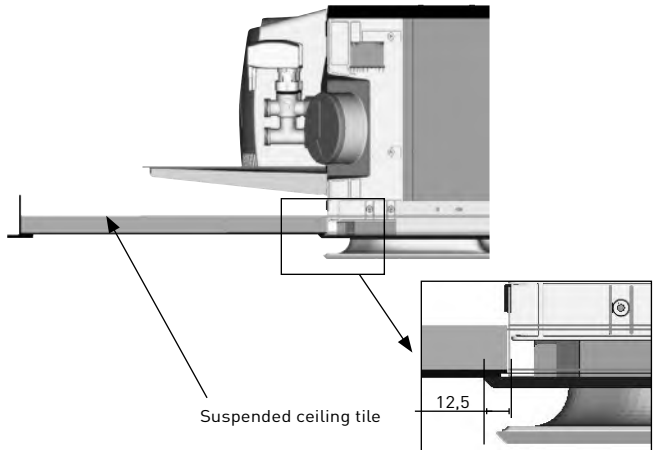

Ø 100 mm fresh air inlet collar, max. air flow 90 m<sup>3</sup>/hr recommended.  
Network balancing system (not supplied by CIAT)

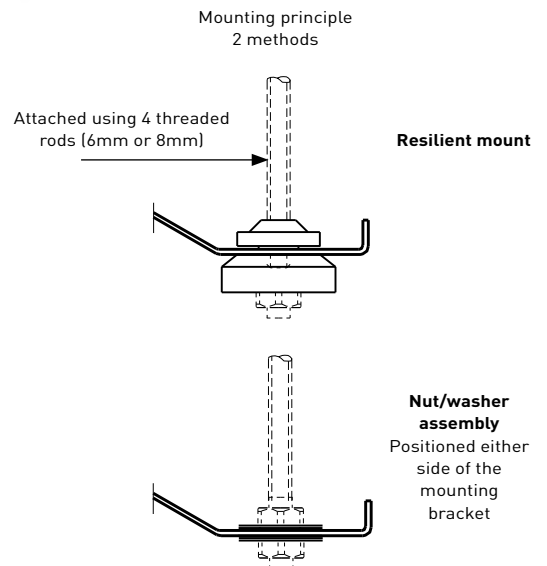
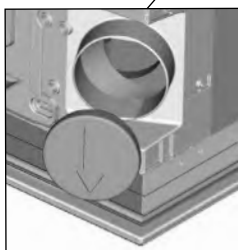

## DIMENSIONS

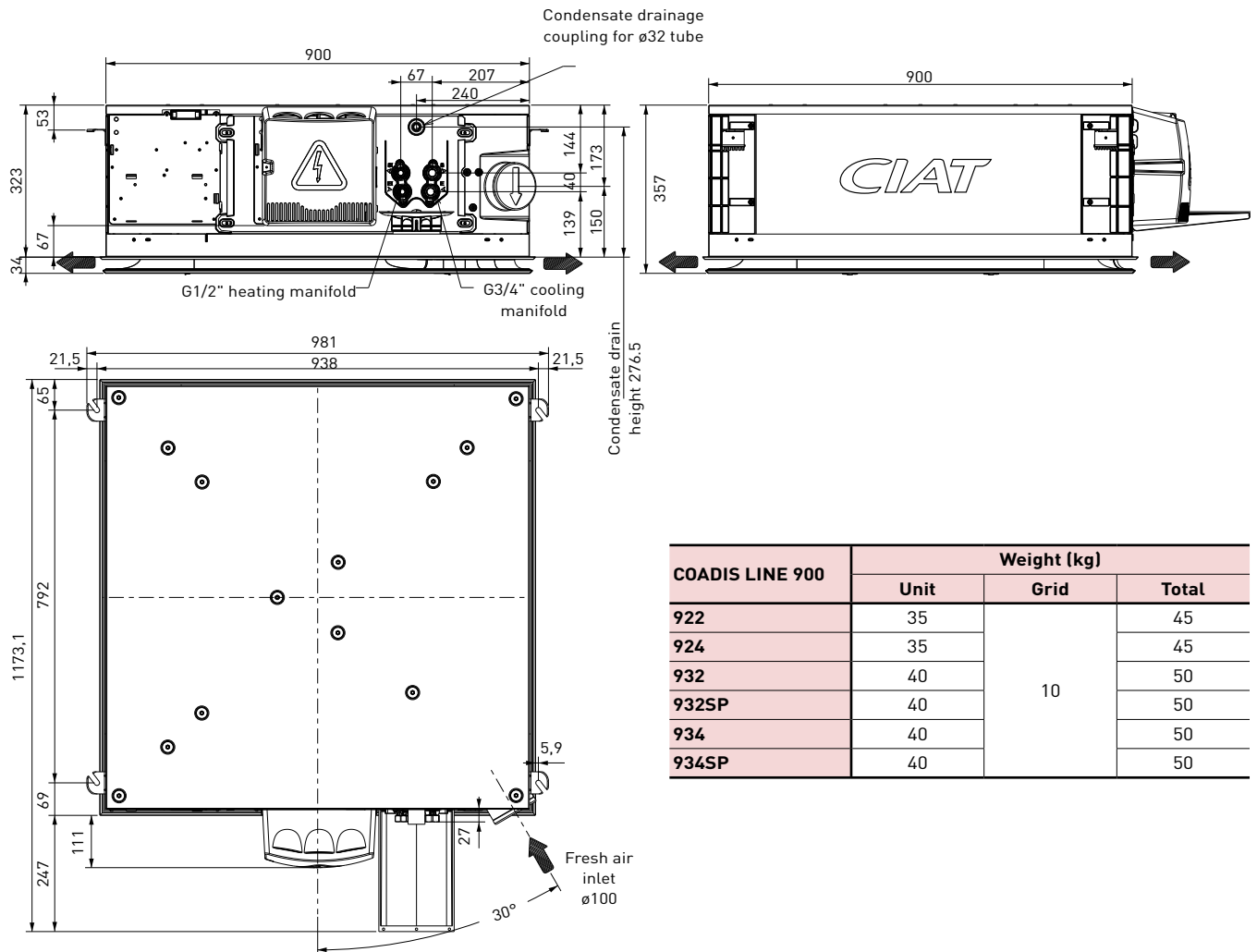

COADIS LINE 900	Weight (kg)		
	Unit	Grid	Total
922	35	10	45
924	35		45
932	40		50
932SP	40		50
934	40		50
934SP	40		50

## Coil capacity (L)

Coadis Line 900	922	932	932SP	924	934	934SP
2-tube coil	2,2	3,5	3,5			
4-tube coil	Cold water coil			2,2	3,5	3,5
	Hot water coil			0,6	0,6	0,6

## Coil connection diameters

Coil coupling type: flat face swivel nuts with a female thread

Valve outlet coupling type: "male flat face" threaded couplings to be used

Coadis Line		922	932	932SP	924	934	934SP
2-tube system	Hot water or cold water coil	G3/4"	G3/4"	G3/4"			
	Cold water coil				G3/4"	G3/4"	G3/4"
4-tube system	Hot water coil				G1/2"	G1/2"	G1/2"

## PIPE AND VALVE POSITIONING

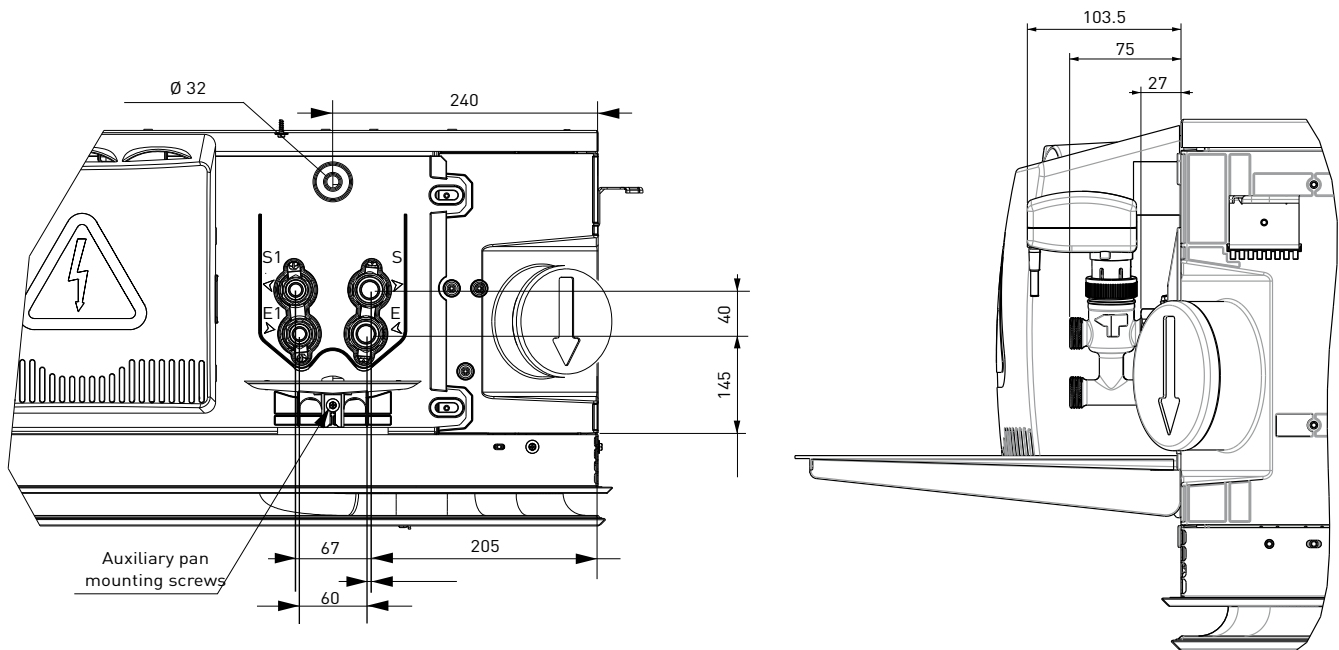

## HYDRAULIC CONNECTIONS WITH VALVE MOUNTING

### Valve and motor assembly (24V or 230V)

- Heating/cooling assembly for valves with 3-point actuators

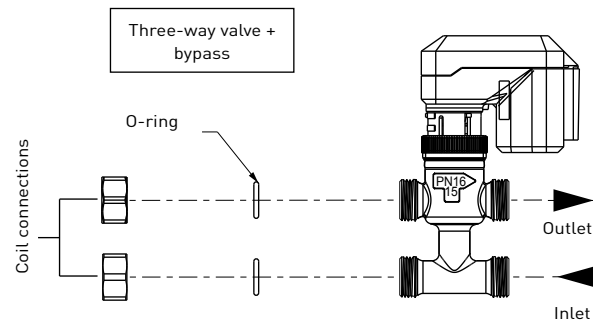
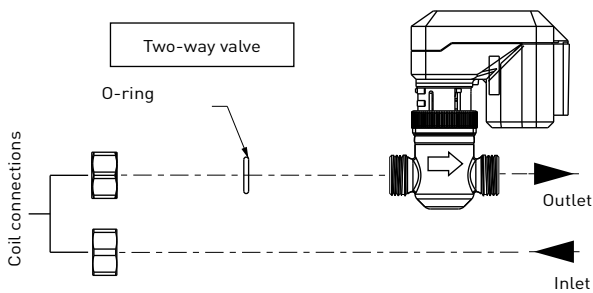

- Heating/cooling assembly for valves with thermal actuators

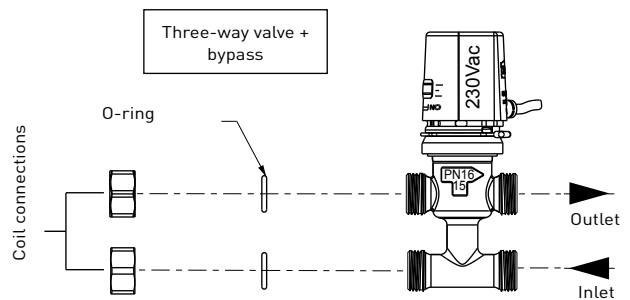
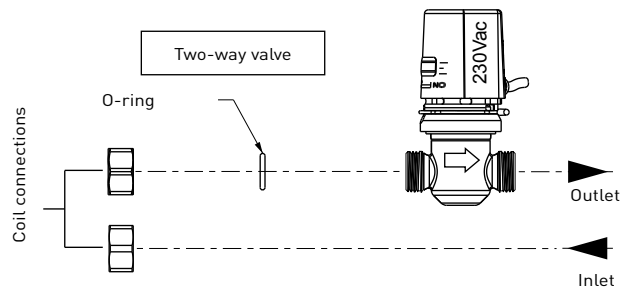

## TECHNICAL CHARACTERISTICS

### Motor electrical specifications

COADIS LINE	Motor code	AC asynchronous motor						HEE brushless motor					
		922	932	932SP <sup>(1)</sup>	924	934	934SP <sup>(1)</sup>	922	932	932SP	924	934	934SP
Input power (W)	V5	102	102	157	102	102	157	51	51	113	51	51	113
	V4	89	89	136	89	89	136	38	38	91	38	38	91
	V3	69	69	119	69	69	119	24	24	72	24	24	72
	V2	53	53	105	53	53	105	15	15	56	15	15	56
	V1	35	35	93	35	35	93	10	10	42	10	10	42
Input current (A)	V5	0,44	0,44	0,68	0,44	0,44	0,68	0,37	0,37	0,39	0,37	0,37	0,39
	V4	0,39	0,39	0,59	0,39	0,39	0,59	0,28	0,28	0,61	0,28	0,28	0,61
	V3	0,30	0,30	0,52	0,30	0,30	0,52	0,20	0,20	0,50	0,20	0,20	0,50
	V2	0,23	0,23	0,46	0,23	0,23	0,46	0,14	0,14	0,39	0,14	0,14	0,39
	V1	0,15	0,15	0,40	0,15	0,15	0,40	0,10	0,10	0,31	0,10	0,10	0,31

Note: Specifications determined for 230V +/-10% - 50Hz supply.

For operation at 60Hz, the power input and rotation speed values are generally higher.

(1) Fan motor assembly not compliant with the ErP2015 Directive

- Motor operating range: minimum return T°C: 0°C  
maximum return T°: 40°C

### Unit information plate

The name plate contains all the information required to identify the unit and its configuration. This plate is placed on the electrics box side.

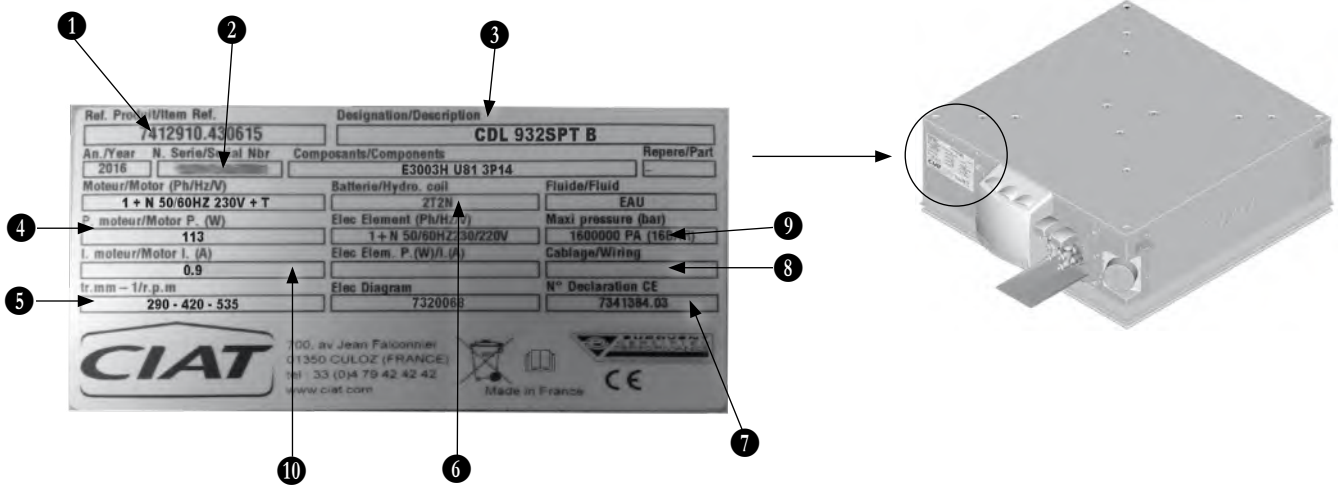

- 1 Code
- 2 Serial number
- 3 Description of the unit
- 4 Nominal motor output
- 5 Motor rotation speed
- 6 Coil type
- 7 Wiring diagram reference
- 8 Motor speed wiring
- 9 Maximum operating pressure
- 10 Electrical heater specifications (if fitted)

## TECHNICAL CHARACTERISTICS

### Condensate drain pump

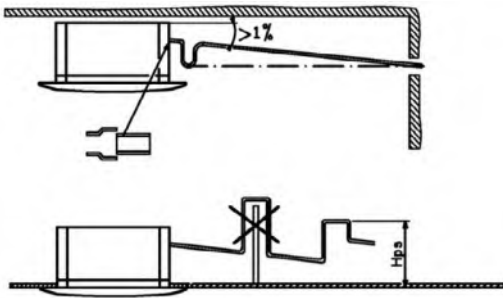
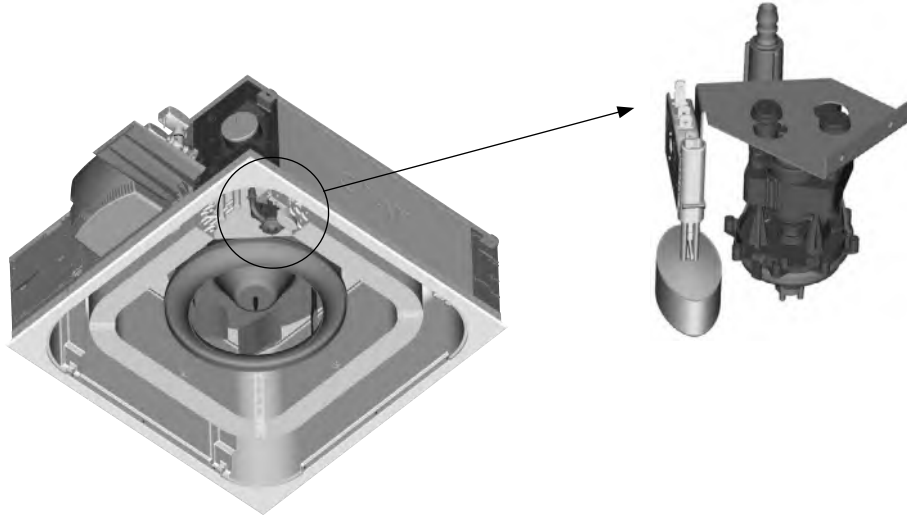

#### TECHNICAL CHARACTERISTICS

Maximum flow rate	100 l/h
Maximum discharge height	120 cm (flow rate = 24 l/h)
Sound level during application at 1 m: (measurements taken at the Sauermann acoustic lab, pump in water)	< or = 30 dBA
Power supply	230 V - 50/60 Hz - 10 W/8W
Insulation class	Double insulation
Detection levels	ON: 18 mm, OFF: 13 mm, AL: 21 mm
Safety contact	0,001-5A for 5V up to 230V
Heat protection (overheating)	90°C (automatic restart)
Service life	15 000 hours (15s OFF, 5s ON)
Protection	IP54
Safety standard	CE
RoHS directive	Compliant
WEEE directive	Compliant

### Electrical heater

2 or 3 single-tube 230/1/50 electrical elements inserted into the aluminium housing and bent around the hydraulic coil.

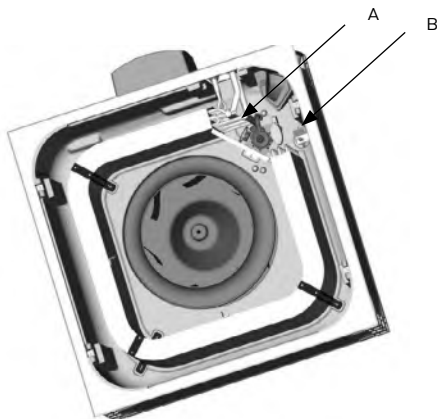

A: temperature limiter with manual reset  
B: temperature limiter with automatic reset



Remove shunt to deactivate a heater  
(reduction of 1000 W)



## TECHNICAL CHARACTERISTICS

### Operating speed selection

#### ■ Asynchronous motor

All speeds are connected and wired to the terminal.

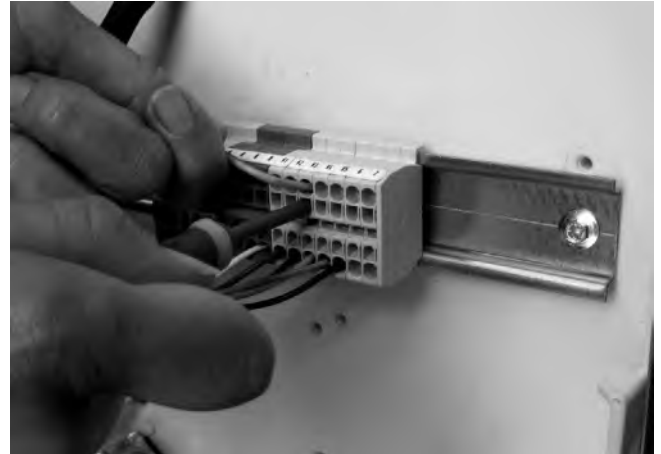
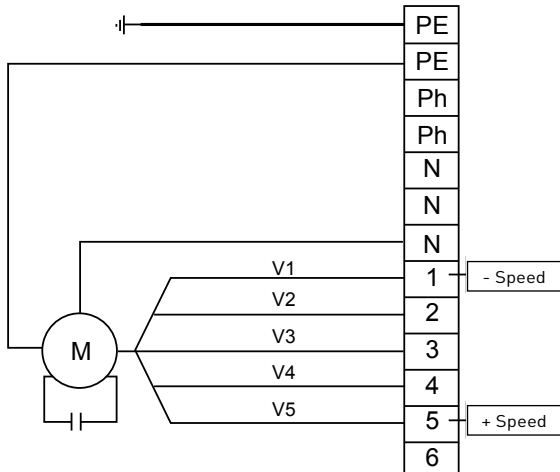

The customer must cable the speeds for the thermostat at the top of the terminal block between V1 and V5

#### ■ HEE motor

Operating speed selection:

- With 0 - 10 V control, adjustment via the controller,
- With 3-speed on/off control, adjustment via the control unit (option).

**Note: For more information, refer to instruction manual N11-47.**

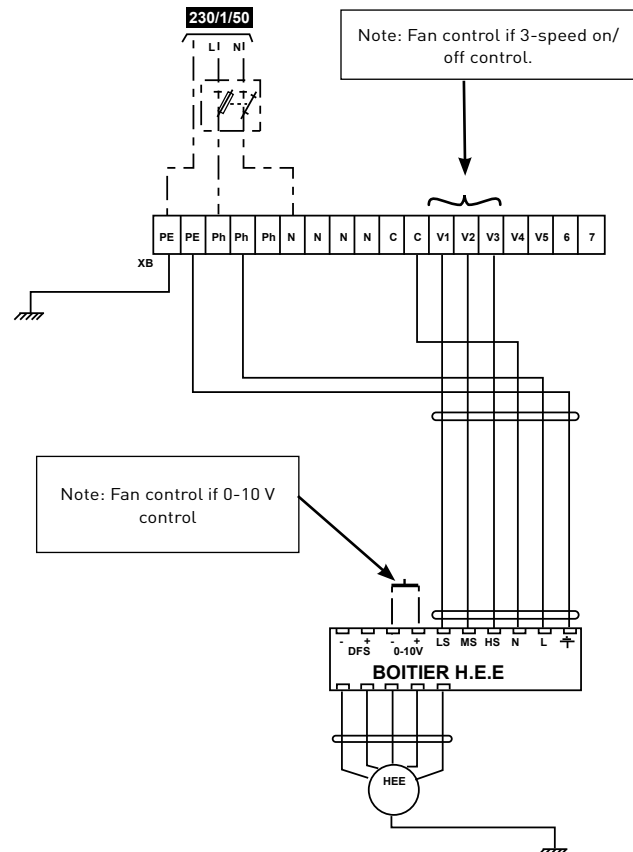
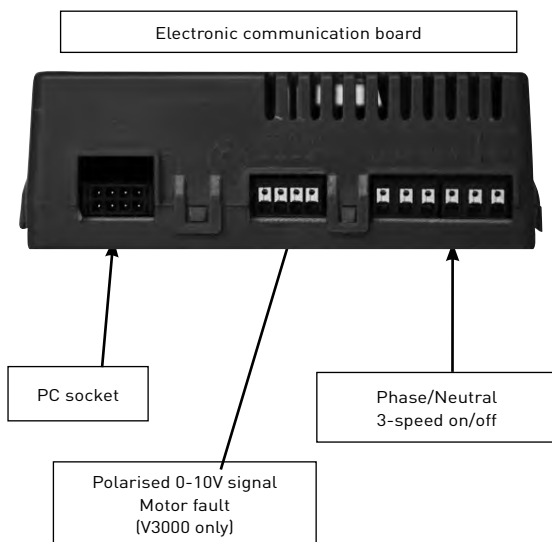

## PERFORMANCE

COADIS LINE	Motor code	Air flow m <sup>3</sup> /h	2-tube system and 4-tube system			Power input W	LW dB (A)	Comfort level (ISO or NR)	Average air temperature rise in K Auxiliary electric heater 230/1/50	
			Cooling capacity (W)		Heating capacity (W)				2R or 3R	
			Total	Sensible						
922	V5	1100	6 165	4 904	6 432	102	51	2000 W (2R)	5,4	
	V4	990	5 677	4 478	6 012	89	48		6,0	
	V3	845	5 093	3 983	5 352	69	46		7,0	
	V2	700	4 403	3 401	4 626	53	42		8,5	
	V1	550	3 673	2 767	3 825	35	39		10,8	
932	V5	1090	7 718	5 689	7 408	102	50	3000 W (3R)	8,2	
	V4	985	7 095	5 194	6 752	89	48		9,0	
	V3	850	6 225	4 517	5 916	69	44		10,5	
	V2	710	5 291	3 808	4 996	53	41		12,5	
	V1	570	4 289	3 066	4 019	35	37		15,6	
932SP <sup>(1)</sup>	V5	1420	9 479	7 182	8 492	157	59	3000 W (3R)	6,3	
	V4	1325	8 986	6 754	7 907	136	56		6,7	
	V3	1225	8 460	6 303	7 405	119	54		7,3	
	V2	1120	7 894	5 833	6 837	105	51		8,0	
	V1	1020	7 287	5 345	6 338	93	48		8,7	
924	V5	1100	6 165	4 904	3 581	102	51			
	V4	990	5 677	4 478	3 380	89	48			
	V3	845	5 093	3 983	3 124	69	46			
	V2	700	4 403	3 401	2 826	53	42			
	V1	550	3 673	2 767	2 490	35	39			
934	V5	1090	7 718	5 689	4 430	102	50			
	V4	985	7 095	5 194	4 192	89	48			
	V3	850	6 225	4 516	3 838	69	44			
	V2	710	5 291	3 808	3 428	53	41			
	V1	570	4 289	3 066	2 963	35	37			
934SP <sup>(1)</sup>	V5	1420	9 479	7 182	4 978	157	59			
	V4	1325	8 986	6 753	4 850	136	56			
	V3	1225	8 460	6 302	4 690	119	54			
	V2	1120	7 894	5 833	4 494	105	51			
	V1	1020	7 287	5 345	4 266	93	48			

Cooling mode: water temperature: 7/12°C, inlet air temperature: 27°C - 19°C (WB)  
 Heating temperature (2T): water temperature: 45/40 °C, inlet air temperature: 20 °C  
 Heating temperature (4T): water temperature: 65/55 °C, inlet air temperature: 20 °C  
 (1) motor not compliant with ErP 2015



Eurovent certified values

CARRIER participates in the ECP programme  
 for LCP-HP Check ongoing validity of  
 certificate: www.eurovent-certification.com

## PERFORMANCE

COADIS LINE	Voltage V	Air flow m <sup>3</sup> /h	2-tube system and 4-tube system			Power input W	LW dB (A)	Comfort level (ISO or NR)	Average air temperature rise in K	
			Cooling capacity (W)		Heating capacity (W)				Auxiliary electric heater 230/1/50	
			Total	Sensible					2R or 3R	
922 HEE	7,1	1100	6 125	4 860	6 472	52	51	2000 W (2R)	5,4	
	6,1	990	5 635	4 434	6 054	38	48		6,0	
	5	845	5 055	3 943	5 390	25	46		7,0	
	3,9	700	4 368	3 365	4 659	15	42		8,5	
	2,7	550	3 649	2 742	3 848	10	39		10,8	
932 HEE	7,1	1090	7 669	5 639	7 454	52	50	3000 W (3R)	8,2	
	6,2	985	7 045	5 144	6 798	38	48		9,0	
	5	850	6 179	4 472	5 957	25	44		10,5	
	3,9	710	5 251	3 770	5 030	16	41		12,5	
	2,7	570	4 262	3 040	4 042	10	37		15,6	
932SP HEE	9,1	1320	8 945	6 711	7 943	92	56	3000 W (3R)	6,8	
	8,2	1225	8 416	6 257	7 442	72	53		7,3	
	7,3	1120	7 847	5 785	6 877	56	51		8,0	
	6,5	1020	7 237	5 295	6 380	42	50		8,7	
	3,6	660	4 960	3 650	4 700	14	39		13,5	
924 HEE	5	845	5 055	3 943	3 136	25	46			
	3,9	700	4 368	3 365	2 838	15	42			
	3,1	600	3 900	2 970	2 620	11	40			
	2,7	550	3 649	2 742	2 499	10	39			
	2	450	3 090	2 240	2 230	9	37			
934 HEE	7,1	1090	7 669	5 639	4 446	52	50			
	6,2	985	7 045	5 144	4 209	38	47			
	5	850	6 179	4 472	3 854	25	44			
	3,9	710	5 251	3 770	3 442	16	40			
	2,7	570	4 262	3 040	2 973	10	37			
934SP HEE	9,1	1320	8 945	6 711	4 863	92	56			
	8,2	1225	8 416	6 257	4 704	72	53			
	7,3	1120	7 847	5 785	4 509	56	51			
	6,5	1020	7 237	5 295	4 283	42	50			
	3,6	660	4 960	3 650	3 342	14	39			

Cooling mode: water temperature: 7/12°C, inlet air temperature: 27°C - 19°C (WB)  
 Heating temperature (2T): water temperature: 45/40 °C, inlet air temperature: 20 °C  
 Heating temperature (4T): water temperature: 65/55 °C, inlet air temperature: 20 °C



Eurovent certified values

CARRIER participates in the ECP programme for LCP-HP Check ongoing validity of certificate: [www.eurovent-certification.com](http://www.eurovent-certification.com)

**CODES**
**With Epure filter**

	Coil →		2 heating or cooling tubes					
	Motor →		HEE motor			5-speed motor		
	Size →		922	932	932SP	922	932	932SP
	Air handling section + auxiliary pan	Code	7344015	7344016	7351393	7344009	7344010	7351311
Diffusion interface VISUAL 360° with EPURE filter	Code	7335537						
VISUAL 360°	Coil →		4 heating and cooling tubes					
	Motor →		HEE motor			5-speed motor		
	Size →		924	934	934SP	924	934	934SP
	Air handling section + auxiliary pan	Code	7344017	7344018	7351394	7344011	7344012	7351313
Diffusion interface VISUAL 360° with EPURE filter	Code	7335537						
	Coil →		2 heating or cooling tubes + electric heater					
	Motor →		HEE motor			5-speed motor		
	Electrical heaters →		2000W	3000W		2000W	3000W	
	Size →		922	932	932SP	922	932	932SP
Air handling section + auxiliary pan	Code	7344019	7344020	7351396	7344013	7344014	7351314	
Diffusion interface VISUAL 360° with EPURE filter	Code	7335537						

**With G3 filter**

	Coil →		2 heating or cooling tubes					
	Motor →		HEE motor			5-speed motor		
	Size →		922	932	932SP	922	932	932SP
	Air handling section + auxiliary pan	Code	7344015	7344016	7351393	7344009	7344010	7351311
Diffusion interface VISUAL 360° with G3 filter	Code	7335538						
VISUAL 360°	Coil →		4 heating and cooling tubes					
	Motor →		HEE motor			5-speed motor		
	Size →		924	934	934SP	924	934	934SP
	Air handling section + auxiliary pan	Code	7344017	7344018	7351394	7344011	7344012	7351313
Diffusion interface VISUAL 360° with G3 filter	Code	7335538						
	Coil →		2 heating or cooling tubes + electric heater					
	Motor →		HEE motor			5-speed motor		
	Electrical heaters →		2000W	3000W		2000W	3000W	
	Size →		922	932	932SP	922	932	932SP
Air handling section + auxiliary pan	Code	7344019	7344020	7351396	7344013	7344014	7351314	
Diffusion interface VISUAL 360° with G3 filter	Code	7335538						

## ACCESSORIES (AVAILABLE SEPARATELY)

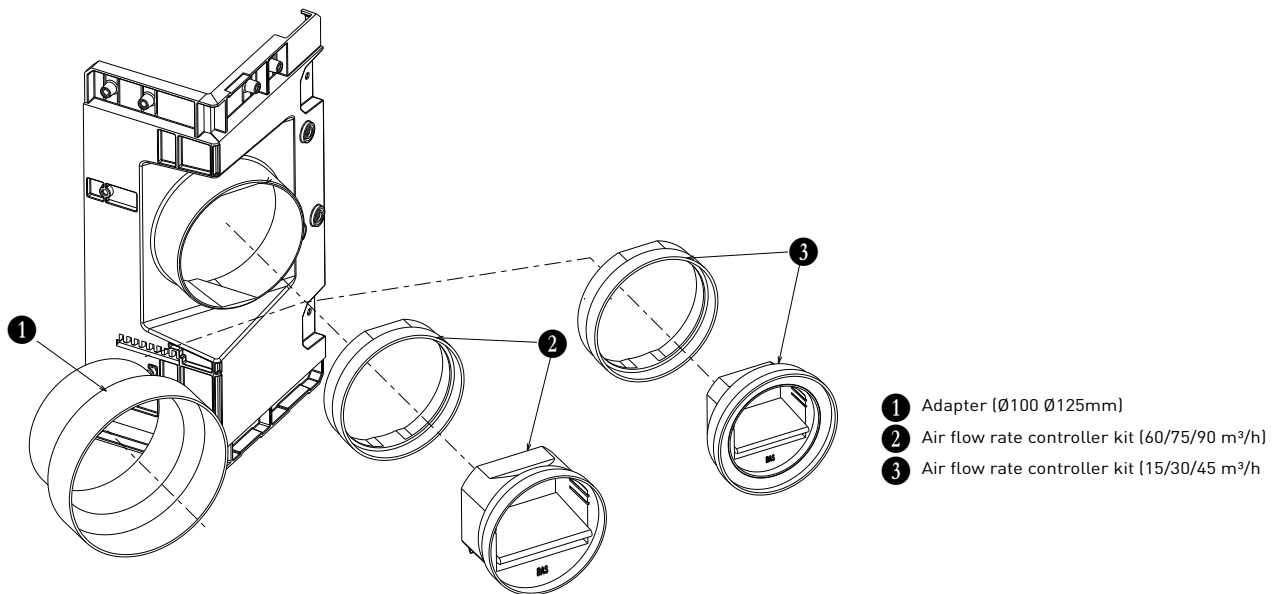

- ❶ Adapter (Ø100 Ø125mm)
- ❷ Air flow rate controller kit (60/75/90 m<sup>3</sup>/h)
- ❸ Air flow rate controller kit (15/30/45 m<sup>3</sup>/h)

Description			
Resilient mounts supplied separately (4 per unit required)		Code	0219453
Self-adjustable module assembly (Ø100mm). Three flow rates available using a set of shims.	15/30/45 m <sup>3</sup> /h	Code	7320014
	60/75/90 m <sup>3</sup> /h	Code	7320015
Adapter sleeve frame (Ø100/125 mm)		Code	7320016
Finishing trim frame + sub-frame for STAFF ceilings		Code	7395055 + 7395057
Speed control unit kit for HEE motor (for on/off 3-speed control only)		Code	7213179

Assembly	Figure	Description	Code	900
<b>For 2-tube coils</b>				<b>G3/4" customer side coupling</b>
All without valve		Two M1 9 mm thick insulated flexible couplings EPDM pipe + PN10 stainless steel braid length 300 mm male coupling with flat face/female rotary coupling on customer side	Code	2 x 7247867
All 3-way valve + bypass		Two M1 9 mm thick insulated flexible connections EPDM pipe + PN10 stainless steel braid length 300 mm Female rotary couplings on both sides	Code	2 x 5202298
All 2-way valve		Two M1 9 mm thick insulated flexible connections EPDM pipe + PN10 stainless steel braid length 300 mm: 1 with male coupling with flat face/female rotary coupling on the customer side 1 with Female rotary couplings on both sides	Code	7247867 + 5202298
<b>For 4-tube coils</b>				<b>Customer side coupling Heating G1/2" Cooling G3/4"</b>
All without valve		EPDM pipe + PN10 stainless steel braid length 300 mm male coupling with flat face/female rotary coupling on customer side Heating: 2 non-insulated Cooling: 2 insulated - M1 9 mm thick	Code	Heating: 2 x 7247868 Cooling: 2 x 7247867
All 3-way valve + bypass		EPDM pipe + PN10 stainless steel braid length 300 mm Female rotary couplings on both sides Heating: 2 non-insulated Cooling: 2 insulated - M1 9 mm thick	Code	Heating: 2 x 7247837 Cooling: 2 x 5202298
All 2-way valve		4 flexible connections, EPDM pipe + PN10 300 mm ling stainless steel braid: 2 with male coupling with flat face / female rotary coupling on the customer side 2 with female rotary couplings on both sides Heating: 2 non-insulated Cooling: 2 insulated - M1 9 mm thick	Code	Heating: 7247868 + 7247837 Cooling: 7247867 + 5202298

## SPECIFICATION TEXT

**Terminal units** must comply with standards and regulations in force, in particular: EN ISO 7730 (thermal comfort), EN 779 (filters), EN 1216 (water coils), EN 50022 (DIN rails), NF C15-100 (electrical components), NF S90-351 (health, airborne contamination control) and the circular DGS no. 97/311 (disinfection of air conditioning systems). Eco designed in accordance with standard EN 14062 and in compliance with environmental certification ISO 14001. They will be manufactured according to the quality assurance standard ISO 9001, EUROVENT and will have the CE mark. The unit will be easy to maintain and the supply air/return air system of the all-in-one type.

The **base** will be designed in high-density PSE with very low TVOC emissions, to provide thermal and sound insulation. The PSE will be classed A+ in accordance with the order of 19th April 2011 concerning the classification of construction materials based on their volatile pollutant emissions. A base panel in galvanised steel to support the internal components and lateral reinforcements in ABS will ensure a rigid construction. It will be easy to wash from the inside and non-erodible. The fire rating will be M1. The components that make up the base must be able to be separated to enable optimal recycling of the materials at the end of life and reduce the environmental impact. Bonded insulation will not be permitted. The dimensions of the base must allow it to be integrated in the centre of four suspended ceiling tiles. Its lightweight design will enable optimal handling and quicker commissioning on site. The mounting brackets, which are equipped with an anti-slip system for the threaded rods, will make the unit easier to fit.

The **Coanda effect diffusion system** will be integrated in the unit. The naturally optimised single-slot design with narrow opening means it does not require adjustment to operate efficiently in any type of room and in all seasons. Any adjustment system that changes the sound of the unit by reducing the supply air section (e.g. dampers) will not be permitted. It will enable horizontal diffusion at an angle of 360° (Visual interface), completely eliminating radiation transfer caused by the walls when the jet is falling vertically outside the occupied space (NF EN 13779) and ensure uniform comfort in line with the stipulations of standard ISO 7730. Its peripheral single-slot design will allow a high rate of induction (injection of ambient air in the air stream) over the entire length so that the desired comfort temperature can be reached more quickly.

The **VISUAL 360°** supply/return interface in RAL 9010 will be completely insulated by a PSE unit which will completely surround the panel. It is removable to enable easy maintenance, and will allow complete access from underneath to all of the internal components (fan motor assembly, coil, condensate pan, etc.) without the need to remove the unit or open the suspended ceiling. Smooth and free from corners where dust could accumulate, the single-slot diffusion system enables quick, easy cleaning. The VISUAL 360° interface will be primarily suited to large spaces, small shopping centres and meeting rooms.

The **air intake** is via a micro-perforated return air grille in RAL 9010, integrated in the unit and hiding the filter. It can be opened easily without tools, allowing the filter to be accessed in under 3 seconds to keep maintenance costs down. The hinge-mounted grille will allow work to be carried out on the unit in complete safety.

The **EPURE function** (air purification system) is to exceed the WHO's recommendations on particle removal, reducing PM2.5 particulates to below 10 µg/m<sup>3</sup> in less than an hour.

It is to be fitted with an air filter made of polypropylene with an M1 fire rating, that will not release glass fibres. The filter should be high energy efficiency and multi-pleated with a filter area of at least 8 times the intake grille surface area. A minimum space of 20 mm must be left between the air intake and the filter in order to ensure that the entire filter area is used, thereby improving the ambient air quality. Its high retention capacity ensures an increased service life (flat filters will not be permitted). In order to reduce waste at the end of the service life, it must be able to be completely incinerated with no sorting of materials necessary. It must be accessible via the return air grille to enable its replacement in less than one minute.

The **water coil** will be made of copper tubes and continuous fins in seamed aluminium. The connections will have one-piece couplings with a 40 mm centre distance and an integrated swivel nut to reduce the number of intermediate couplings, thereby reducing the risk of leaks (direct assembly of valves). The coils will be equipped with air bleed and draining valves. They will be tested under extreme conditions with a minimum test pressure of 24 bar. In order to reduce energy consumption and simplify commissioning, it will be possible to fit them with automatically adjusted differential pressure valves to ensure the water flow rate is maintained, once it has been set with the manual handle.

The **main condensate pan** will be in high-density sealed non-corrodible PSE. Its naturally sloped design will allow it to drain condensate directly to the integrated condensate drain pump. It will be possible to remove the main pan from underneath without the need to open the suspended ceiling.

Mounted on the outside of the unit, the **auxiliary condensate pan** in ABS will enable the condensate produced by the cold water control valve to be recovered. The condensate will also be drained by the condensate drain pump.

The **additional electric heater** running in 230V single-phase must be shielded with stainless steel. It should be placed downstream of the water coil in order to save energy (for simultaneous hot water and auxiliary electric heater usage). The unit is to be fitted with safety limiters that comply with the applicable standards. All electric heaters with incandescent wires or sacrificial fuses will be prohibited. It will be possible to reduce the power of the electric heater on site.

## SPECIFICATION TEXT

---

The **fan motor assembly**, mounted on anti-vibration mounts, will be fitted with a low-consumption HEE motor with BLAC (BrushLess Alternate Current) technology, which offers more linear torque progression and a lower operating sound level than BLDC (Brushless Direct Current) technology. All BLDC motors will be prohibited. Single-phase 230V 50/60Hz, it may be controlled by a progressive control signal 0-10V or 3-speed ON/OFF with no need for an additional electronic board. It will be fitted with an automatic overload protection with alarm report via KNX bus. The centrifugal impeller with airfoil blades will be balanced to prevent noise from vibrations. The system mounting it on the drive shaft will be fitted with a foolproofing device which prevents installation if incorrectly positioned, in order to simplify maintenance. The fan motor assembly will be removable from underneath.

An **electrics box** that is enclosed and of large dimensions, fitted with a DIN rail, will be able to accommodate and protect all the control components from dust. The safety of the electrical cables must be ensured using cable glands. The electrical and hydraulic feeds must both be on the same side to facilitate maintenance operations. In order to ensure reliability, the control will be factory-fitted (except for the room terminal) to eliminate any risks of leaks, for electrical safety and for the proper protection of components.

The **fresh air inlet** connects through a smooth metal sleeve (with no flow control) or via a self-adjusting spigot and module assembly designed to supply the determined flow rate with a  $\Delta P$  between 50 and 100 Pa.

**Resilient mounts** will be placed between the unit's mountings and the threaded rods to prevent any transmission of noise.

### Guarantees

The manufacturer guarantees the equipment's performance, and will provide the documents attesting to the equipment's compliance with the attached specifications and with the STANDARDS, in particular the heating and cooling capacity (total and sensible), the air flow, the motor power input, the efficiency of the filters and the sound power spectrum. Using a simulation tool, the manufacturer of the terminal units must be able to give the relevant comfort indices or the values in compliance with the standard EN ISO 7730. The system start-up and maintenance guide for the unit must be in the language used in the country of installation. The manufacturer's technical specifications and the equipment's sound pressure must be given in the documents to be appended to the submission.

The quality management system of this product's assembly site has been certified in accordance with the requirements of the ISO 9001 standard (latest current version) after an assessment conducted by an authorized independent third party.

The environmental management system of this product's assembly site has been certified in accordance with the requirements of the ISO 14001 standard (latest current version) after an assessment conducted by an authorized independent third party.

The occupational health and safety management system of this product's assembly site has been certified in accordance with the requirements of the ISO 45001 standard (latest current version) after an assessment conducted by an authorized independent third party.

Please contact your sales representative for more information

Order No.: NA24712A, 10.2024. Supersedes order No.: NA19712A, 03.2019.

Carrier, Rte de Thil - 01120 Montluel, France.

Manufacturer reserves the right to change any product specifications without notice.

The illustrations in this document are for illustrative purposes only and not part of any offer for sale or contract.

The manufacturer reserves the right to change the design at any time without notice.